

Instruction manual

**DYNACIAT LG - LGP**

**DYNACIAT<sup>power</sup>**

**LG - LGP**



NA 10.59 G

06 - 2016



<b>CONTENTS</b>	<b>PAGE</b>
<b>1 INTRODUCTION</b>	<b>2</b>
<b>2 SHIPMENT OF THE UNIT</b>	<b>2</b>
<b>3 RECEIPT OF GOODS</b>	<b>3</b>
3.1 Checking the equipment	3
3.2 Identifying the equipment	3
<b>4 SAFETY INSTRUCTIONS</b>	<b>3</b>
<b>5 MACHINE COMPLIANCE</b>	<b>3</b>
<b>6 WARRANTY</b>	<b>3</b>
<b>7 UNIT LOCATION</b>	<b>4</b>
<b>8 HANDLING AND POSITIONING</b>	<b>4</b>
<b>9 LOCATION</b>	<b>5</b>
9.1 Location of the unit	5
<b>10 OPERATING LIMIT</b>	<b>6</b>
10.1 Operating range.	6
10.2 Condenser limit.	6
10.3 Evaporator Limit	6
10.4 Minimum/maximum water flow rates	7
<b>11 LOCATION OF THE MAIN COMPONENTS</b>	<b>7</b>
<b>12 MAIN COMPONENTS OF THE REFRIGERATING CIRCUIT</b>	<b>7</b>
<b>13 HYDRAULIC CONNECTIONS</b>	<b>8</b>
13.1 Diameter of hydraulic and refrigerant connections	8
13.2 FLANGE/VICTAULIC adapter kit for DYNACIAT <sup>power</sup> (OPTION)	9
<b>14 ANTI-FROST PROTECTION FOR THE INSTALLATION</b>	<b>9</b>
<b>15 ELECTRICAL CONNECTIONS</b>	<b>10</b>
15.1 Power connection	10
15.2 Customer connection for remote control functions.	10
<b>16 CONTROL AND SAFETY DEVICES</b>	<b>11</b>
16.1 Electronic control and display module	11
16.2 Main functions	12
16.3 Safety device management	12
16.4 DYNACIAT LG, LGP 120V to 500V 2-way valve kit	13
16.5 Phase controller kit	13
16.6 Location of the safety sensors and devices	13
16.7 Adjusting the control and safety devices	16
<b>17 COMMISSIONING</b>	<b>16</b>
17.1 Startup and commissioning	16
17.2 Essential points to check	17
<b>18 TECHNICAL AND ELECTRICAL SPECIFICATIONS</b>	<b>18</b>
<b>19. SERVICING AND MAINTENANCE</b>	<b>20</b>
19.1 Operating readings for DYNACIAT et DYNACIAT <sup>power</sup>	20
19.2 Unit maintenance and servicing	20
<b>20 ECODESIGN</b>	<b>22</b>
<b>21 PERMANENT SHUTDOWN</b>	<b>22</b>
<b>22 TROUBLESHOOTING OPERATING PROBLEMS</b>	<b>22</b>
<b>23 INSTALLATION DIAGRAM FOR DYNACIAT AND DYNACIAT<sup>power</sup> LG, LGP</b>	<b>24</b>
23.1 Cooling installation with drycooler	24
23.2 Cooling mode (Heating and cooling)	25
23.3 Heating mode (Heating and cooling)	25

## 1 INTRODUCTION

The **DYNACIAT** and **DYNACIAT<sup>power</sup> LG and LGP series** water chiller units and heat pumps can meet the air conditioning and heating needs of residential and office buildings and also meet the requirements for industrial processes.

The **DYNACIAT** and **DYNACIAT<sup>power</sup> LG, LGP** units are liquid chillers with water cooled condensers which guarantee safe and reliable performance in the defined area of application.

**All the units are factory tested and checked. They are supplied with a full refrigerant charge.**

All units meet standard EN 60-204 and standard EN378-2 as well as the following European directives:

- Machinery 2006/42 EC
- EMC 2014/30/EU
- LVD 2014/35/EU
- RoHS 2011/65/EC:
- PED 2014/68/EU, see table below

LG - LGP	DYNACIAT 120V to 600V	DYNACIAT <sup>power</sup>			
		700V to 1000V	1100V to 1200V	1400V to 1800V	2100V to 2400V
Category	II	II	III	II	III

### Pressure and temperature :

**Test pressure (TP):** because of the harmful effects it has on the unit, this test is carried out on a model representative of all 3 x PS assemblies in compliance with § 5.3.2.2 a and 6.3.3 iii of standard 378-2.

**Shipment temperature:**

DYNACIAT 120V to 600V → Min. -30°C - Max. +50°C.

DYNACIAT<sup>power</sup> 700V to 2400V → Min. -30°C - Max. +50°C.

**Storage temperature:**

DYNACIAT 120V to 600V → Min. -30°C - Max. +50°C.

DYNACIAT<sup>power</sup> 700V to 2400V → Min. -30°C - Max. +50°C.

**Operating temperature:**

Refer to the section entitled "10 Operating limits" in this manual.

Technicians who install, start up, operate and service the unit must possess the necessary training and certifications, understand the instructions given in this manual and be familiar with the specific technical characteristics of the installation site.

If they are to work on the unit's refrigeration circuit, such training and certification must meet the requirements of Regulation (EC) 842/2006.

## 2 SHIPMENT OF THE UNIT

During shipment, the unit must be securely strapped in place to prevent it moving and to protect it from damage.

If the unit is shipped in a container, the container must be easy to load and unload.

Do not use these accessories to lift the device.

### 3 RECEIPT OF GOODS

#### 3.1 Checking the equipment

Check the unit for any damage or missing components upon delivery. Note any damaged or missing parts on the delivery slip.

**IMPORTANT:**

You must notify the carrier of any damage and/or missing parts by registered letter within three days of the delivery date. Furthermore, ensure the unit is not stored in an outdoor location exposed to the elements.

#### 3.2 Identifying the equipment

**Name plate:**

Each unit has a manufacturer's name plate (A) bearing the unit's identification number (serial number) and description.

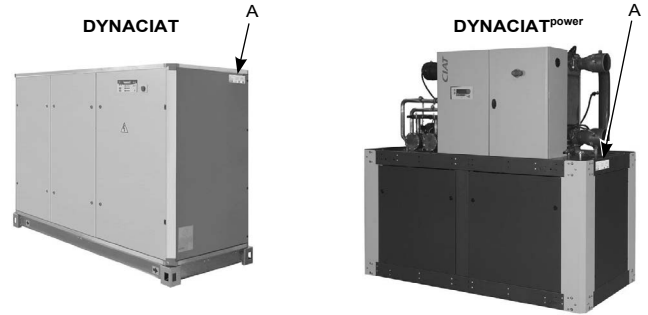

Make sure this information matches that on the order.

Markings (data plate, punch marks, labels) must remain visible. They must not be altered, removed or modified.

**Key:**

- **Désignation/Description** : Unit type.
- **An(Year)** : Year manufactured
- **N° série/Serial Nbr** : Production number (please state this number in all correspondence)
- **Refrigerant** : Refrigerant fluid type.
- **Refrigerant kg/TeqCO2**: Refrigerant content in kg and in tonnes of CO2 equivalent
- **BP/LP Mini / PSM/MOP** : For the low pressure circuit:
  - BP/LP. Mini = Minimum operating pressure in bar.
  - PSM/MOP = Maximum permissible pressure in bar. (OP as per PED 2014/68/E)
- **HP Maxi PSM/MOP** : For the high pressure circuit:
  - HP. Maxi = Maximum operating pressure in bar.
  - PSM/MOP = Maximum permissible pressure in bar. (OP as per PED 2014/68/E)
- **kW Absorbee/Input kW** : Power input in kW.
- **Tension/Voltage** : Power supply.
- **Intensite/Current A** : Nominal current in A.
- **Pression/Pressure Test** : See § "Pressure and temperature" on the previous page
- **Service/Working kg** : Operating weight of the unit, in kg.
- **Temperatures Min/Max** : See § "Pressure and temperature" on the previous page.
- **IP** : Machine electrical protection rating.
- **No CE** : Notified Body number.

Ref. produit/Item Nbr		Designation/Description	
3025277 286282		LG 1200V R410A	
An(Year)	N. Serie/Serial Nbr	No Produit	
	02438040/0001		
Refrigerant	R410A	kW Absorbee/Input kW	Service/Working kg
		46.6	1088
Refrigerant kg / TeqCO2	13.5 + 14.0 / 28.2+29.2	Tension/Voltage	Temperature Min/Max
		3 50HZ 400V	CF NOTICE
BP/LP Mini	PSM/MOP	Intensite/Current A	IP
2.5 BAR / 29.5 BAR		140	21
HP Maxi	PSM/MOP	Pression/Pressure Test	No CE
42 BAR / 42 BAR		PT=3XPS CF NOTICE	0060
Contient des gaz fluorés à effet de serre / Contains fluorinated greenhouse gases			
		30, av Jean Falconnier 01300 CULOZ (FRANCE) Tél.: 33-(0)4-79-42-42-42 www.ciat.com	

Please include the identification number in all correspondence with CIAT.

### 4 SAFETY INSTRUCTIONS

To avoid any risk of accident during installation, start-up and adjustments, the following equipment specifics must be taken into account:

- Pressurised refrigerant circuits
- presence of refrigerant
- Presence of electrical voltage

Only experienced and qualified persons may work on such equipment.

The recommendations and instructions in this manual and on each drawing provided with the unit must be followed.

In the case of units with pressure equipment or components, we

recommend that you contact your professional organisation for information on the regulations that apply to operators or owners of pressure equipment or components. The specifications of this equipment or components are given on the name plate or in the regulatory documentation provided with the product.

A fire protection device is fitted as standard on the units.

**IMPORTANT:**

Before working on the unit, ensure the power has been disconnected at the main disconnect switch in the unit's electrical cabinet.

### 5 MACHINE COMPLIANCE

Refer to the document entitled "Declaration of conformity" supplied with your equipment.

### 6 WARRANTY

The warranty is effective for a period of 12 months from the date the unit is first commissioned into service provided said date occurs within three months of the invoice date.

It is effective for a period of 15 months from the unit invoice date in all other cases.

**NOTE:** Refer to our general terms and conditions of sale for further information.

## 7 UNIT LOCATION

These units are typically used for refrigeration and are not required to withstand earthquakes. Earthquake resistance has therefore not been checked.

Before setting up the unit in its intended location, the installer must check the following points:

- These units are designed to be installed and stored inside a machine room that is sheltered from frost and the elements. Failure to do so will incur the loss of the manufacturer's warranty.
- The surface area of the ground or structure must be strong enough to bear the unit's weight.
- The unit must be perfectly level.
- There must be sufficient free space around and above the unit to allow servicing and maintenance (see dimensional drawing provided with unit).
- The room housing the unit must comply with the requirements of regulation EN 378-3 and other specifications applicable at

the installation site.

- The selected location must not be liable to flooding. Provisions must be made for the drainage of defrosting water.
- Sound level:
  - Our units are designed to operate quietly.
  - In the installation design, you must take into account the interior environment for radiated noise and the building type for airborne and solid-borne noise transmission.
  - To ensure vibrations transmitted by solid materials are reduced as much as possible, it is strongly recommended to fit anti-vibration mounts between the unit support and frame (see the section on anti-vibration mounts), as well as flexible couplings on the hydraulic piping.
  - Have an analysis carried out by an acoustics engineer.

**IMPORTANT:** The ambient temperature must not exceed 50°C during the unit's off cycles.

## 8 HANDLING AND POSITIONING

To raise the unit, attach the slings to the designated handling holes.

The data relating to the centre of gravity and the position of the anchorage points are given on the dimensional drawing.

### Detailed view of the anchorage point for handling

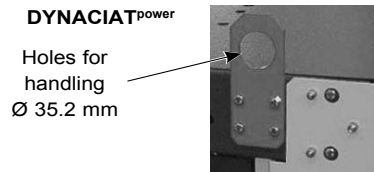
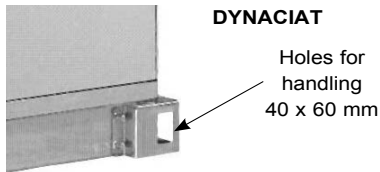

The unit can be handled with a forklift truck (check the maximum permissible load of the forklift).

In this case, it is important that the necessary precautions be taken to avoid the unit sliding on the forks of the forklift. You must observe the instructions given on the label affixed to the unit. Failure to observe these instructions may result in the unit tipping over and causing physical injury.

### WARNING:

- Attach the slings only to the anchorage points intended for this purpose and which are designated on the unit.
- Use slings with a suitable lifting capacity and follow the lifting instructions on the drawings provided with the unit.
- Caution: the centre of gravity is not necessarily at the middle of the unit and the forces applied to the slings are not always

identical.

- Raise and set down the unit carefully. Take care not to tilt it by more than 15°, as this could adversely affect its operation.
- To avoid damaging the casing, use textile slings with shackles.
- Use a frame with an adjustable centre of gravity to keep the slings away from the top of the unit.
- Always protect the unit casing (panels, posts, front access door) from damage during handling. Only the base frame is designed to withstand handling.
- Safety when lifting can only be guaranteed if all these instructions are followed.

Otherwise, there is a risk of damage to the equipment and personal injury.

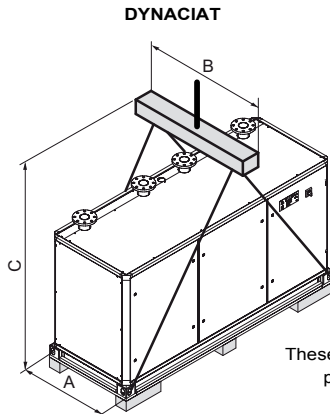

These diagrams are provided for illustrative purposes only. Always refer to the pictograms on the unit

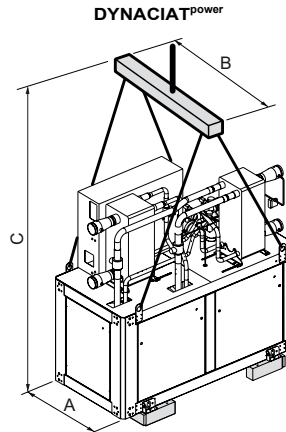

DYNACIAT LG - LGP	120V	150V	200V	240V	300V	350V	400V	500V	540V	600V
A						883				
B						1100				
C						1700				

DYNACIAT <sup>power</sup> LG - LGP	700V	800V	900V	1000V	1100V	1200V	1400V	1600V	1800V	2100V	2400V
A	996										
B	1400										
C	2580						2930			2860	

Weight (empty), see section 9.1.1

For the DYNACIAT, once the unit is put into position, the locking bolts must be removed (see photo below).

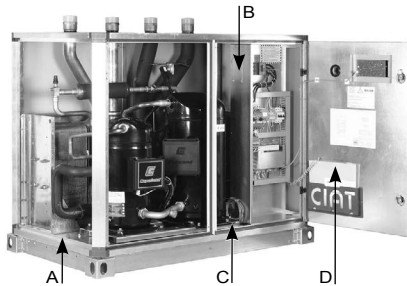

- A = Transport screw (red), must be removed before commissioning.
- B = Electrical supply plate.
- C = Outdoor temperature sensor (length 6 m) / necessary for determining water properties according to climatic conditions.
- D = Documents that must be read before switching on for the first time

## 9 LOCATION

### 9.1 Location of the unit

#### 9.1.1 Dimensions and ground mounting of the frame

The frame may be affixed to the ground. (Mounts with studs not supplied by CIAT). The hardness is to be defined according to the unit's weight and centre of gravity.

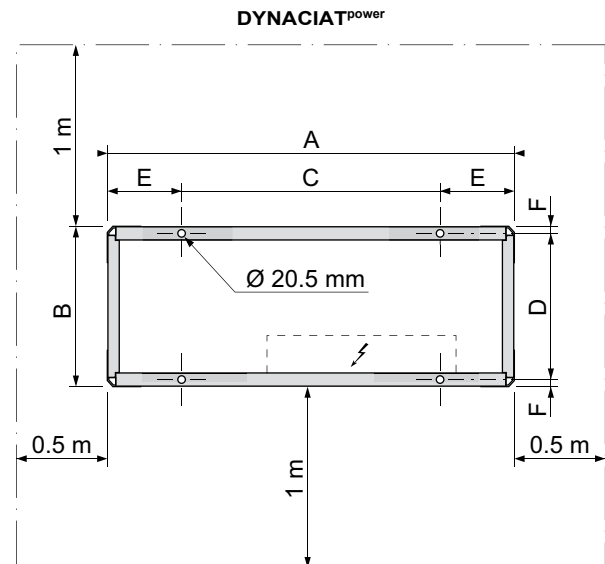
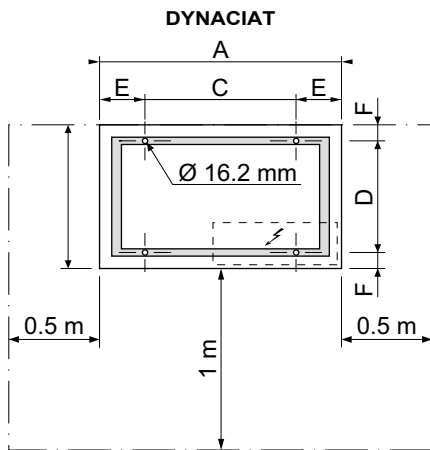

Free space to be maintained to allow sufficient room for maintenance of the unit.  
It is important that the units are installed with the necessary clearances.

DYNACIAT LG - LGP	120V	150V	200V	240V	300V	350V	400V	500V	540V	600V	
A	798		1492						2380		
B	883		883						883		
C	526		920						1808		
D	763		763						763		
E	136		286						286		
F	60		60						60		
Empty weight	Kg	230	300	385	390	590	620	665	735	930	1125
Operating weight	Kg	240	312	400	406	617	650	703	780	990	1190

DYNACIAT <sup>power</sup> LG - LGP	700V	800V	900V	1000V	1100V	1200V	1400V	1600V	1800V	2100V	2400V	
A	2099						2499			3350		
B	984						984			984		
C	1271						1671			2366		
D	916						916			916		
E	414						414			492		
F	34						34			34		
Empty weight	Kg	1044	1156	1189	1312	1363	1425	1613	1708	2284	2376	2418
Operating weight	Kg	1088	1205	1246	1378	1436	1510	1713	1818	2472	2588	2637



### 9.1.2 Anti-vibration mounts (supplied as standard for DYNACIAT, optional for DYNACIAT<sup>power</sup>)

Anti-vibration mounts must be installed beneath the unit in the case of applications with extremely low vibrations. DYNACIAT models are designed for “noiseless” assembly using the mounts in machine’s frame. For DYNACIAT<sup>power</sup> models, the mounts must be placed at the locations illustrated below.

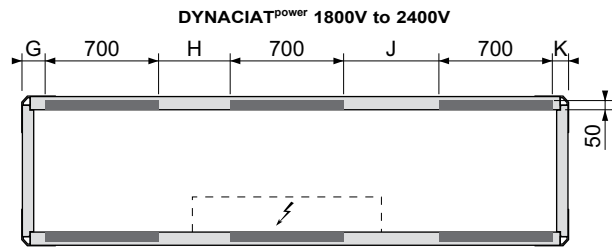
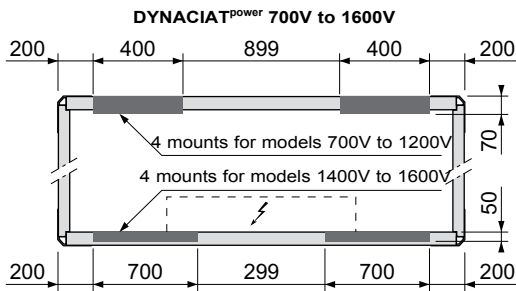

DYNACIAT <sup>power</sup> LG - LGP	G	H	J	K
1800V	100	440	585	125
2100V	100	585	440	125
2400V	125	440	585	100

## 10 OPERATING LIMIT

### 10.1 Operating range.

The graph below represents the area of application (under full load) of the units.

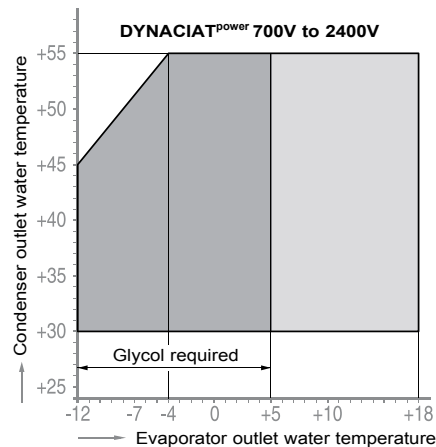
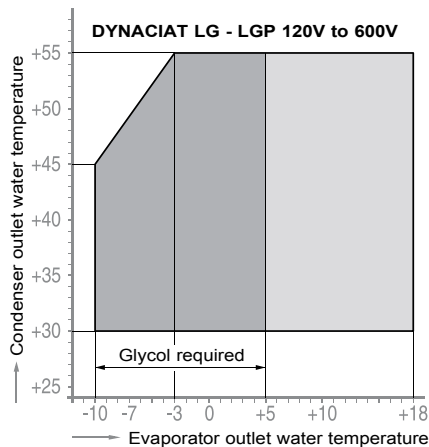

### 10.2 Condenser limit.

DYNACIAT et DYNACIAT <sup>power</sup>	LG	LGP
Water cooled condenser ΔMin. T °C / ΔMax. T °C	Yes - 5 / 10 <b>The customer must do everything possible to ensure a minimum water inlet temperature of 25°C on the condenser side.</b>	
Without condenser / Condensation temperature Min. °C / Max. °C	No	
Evaporator ΔMin.T °C / ΔMax. T °C	Variable according to water outlet temperature. See evaporator limit curves	

### 10.3 Evaporator Limit

The curves below show the minimum and maximum allowable temperature differences for chilled water or glycol/water solution based on the water outlet temperature.

— — — DYNACIAT  
 - - - DYNACIAT<sup>power</sup>

#### Example:

For a water outlet temperature of +5°C

- Δ minimum T 2.6 °C, which gives a water temperature of 7.6 / 5 °C
- Δ maximum T 6 °C, which gives a water temperature of 11 / 5 °C

If the temperature difference calculated is outside the two curves, contact us.

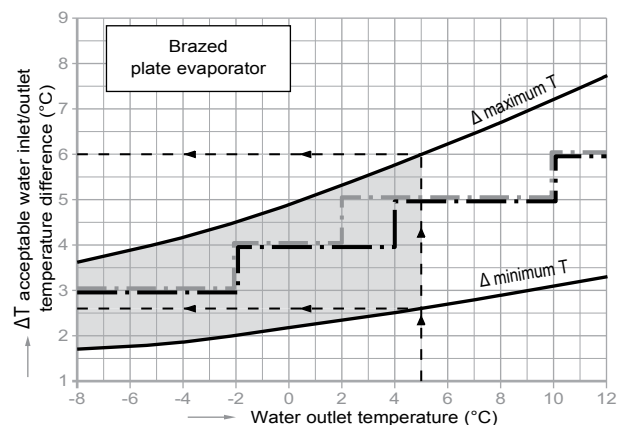



### 10.4 Minimum/maximum water flow rates

The flow rates in the exchangers must be maintained between the values given below.

DYNACIAT LG - LGP		120V	150V	200V	240V	300V	350V	400V	500V	540V	600V
Evaporator	min. m <sup>3</sup> /h	3.5	4.8	6.2	7	9.5	10.9	12.4	15.2	16.4	19.1
	max. m <sup>3</sup> /h	11.2	14.6	19.8	22.2	29.2	34	38.4	47.5	51.1	58.4
Condenser	min. m <sup>3</sup> /h	3.1	4.1	5.4	6.1	8.2	9.4	10.7	13.1	14.3	16.3
	max. m <sup>3</sup> /h	8.5	11.1	15.1	17	22.3	26	29.4	35	39.1	44.6

DYNACIAT <sup>power</sup> LG - LGP		700V	800V	900V	1000V	1100V	1200V	1400V	1600V	1800V	2100V	2400V
Evaporator	min. m <sup>3</sup> /h	22	26	29	33	35	38	44	51	61	68	74
	max. m <sup>3</sup> /h	70	81	92	105	113	124	137	151	150	150	150
Condenser	min. m <sup>3</sup> /h	19	22	25	28	31	33	38	43	52	59	66
	max. m <sup>3</sup> /h	64	74	84	95	103	112	129	143	150	150	153

### 11 LOCATION OF THE MAIN COMPONENTS

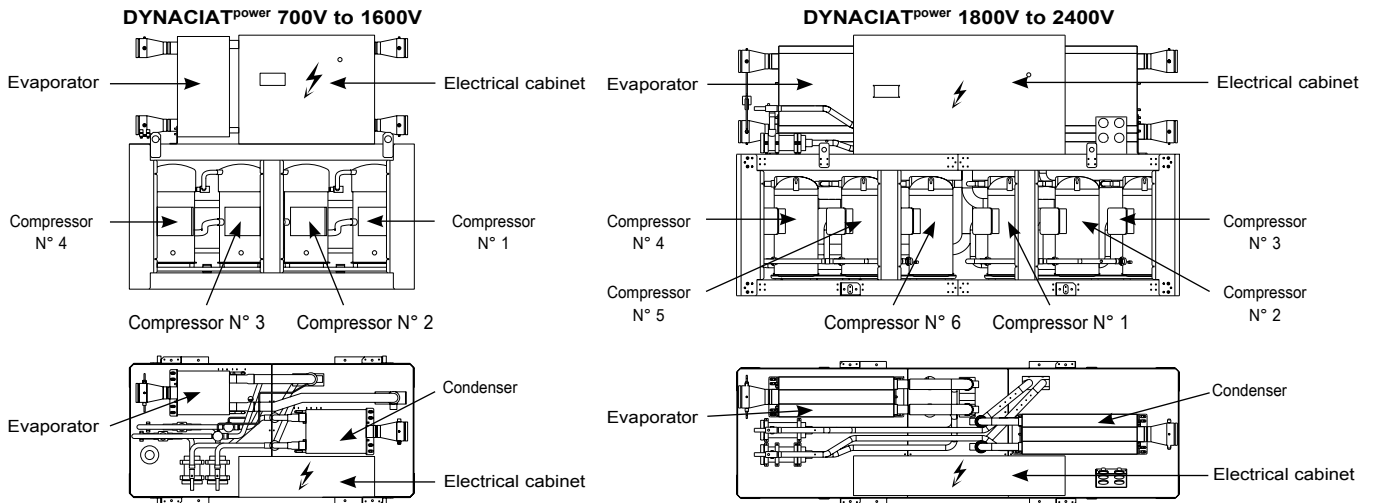

### 12 MAIN COMPONENTS OF THE REFRIGERATING CIRCUIT

#### Compressor

The DYNACIAT LG, LGP and DYNACIAT<sup>power</sup> units use hermetically sealed SCROLL compressors.

#### Oil

The compressor is lubricated with a polyester oil, (POE) type 160SZ for the DYNACIAT<sup>power</sup> 700V to 1200V. This oil will be 3MAF type (32 cSt) for DYNACIAT LG - LGP and DYNACIAT<sup>power</sup> 1400V to 2400V.

If necessary, top up the compressors with ICI Emkarate RL 32 CF oil or Mobil EAL Arctic 22 CC oil if no 3MAF is available for R410A models.

#### Refrigerant

The DYNACIAT LG, LGP 120V to 600V and DYNACIAT<sup>power</sup> 700V to 2400V operate with R410A.

The Global Warming Potential (GWP) is 2088 GWP for R410A in compliance with norm EN378-1

#### Exchangers

With the DYNACIAT, the evaporators and condensers are single-circuit brazed-plate heat exchangers.

With the DYNACIAT<sup>power</sup>, the evaporators and condensers are double-circuit brazed-plate heat exchangers.

The evaporators are insulated with 10 mm thick polyurethane foam. 19 mm insulation is available as an option (standard fitment for operation with low temperature glycol water below 0 °C).

The heat transfer fluid must be filtered and internal inspections must be carried out.

Repairs or modifications of any kind to the plate heat exchangers are prohibited. Only replacement of the heat exchanger with another original heat exchanger and by a qualified technician is authorised.

If the heat exchanger is replaced, this must be noted in the maintenance booklet.

#### Thermostatic expansion valve

The expansion valves have a thermostatic charge (MOP) allowing the maximum possible evaporation pressure to be obtained in order to protect the compressor.

Every unit is fitted with packaged hermetically-sealed thermostatic expansion valves that are set in the factory to maintain superheat of 5 to 7°C under all operating conditions.

#### Dryer

All units are fitted as standard with a dryer filter (on the DYNACIAT<sup>power</sup> the filter unit has a replaceable element) whose role is to keep the refrigerating circuit clean and free of moisture. The dryer filter consists of aluminium oxide and a molecular sieve that neutralises any acids in the refrigeration circuit.

#### Liquid sight glass

Located on the liquid line just after the filter dryer, the liquid sight glass is used to monitor the charge in the unit and to check for moisture in the circuit. Bubbles in the sight glass mean that the refrigerant load is insufficient or that non-condensable gases are in the refrigeration circuit. If the sight glass indicator paper changes colour, there is moisture in the circuit.

**Warning:** Some of the sight glasses may turn yellow when the machine is powered off as their sensitivity is affected by the fluid temperature.

The sight glasses should return to green after the unit has been operating for a few hours.

If the sight glasses remain yellow, there is excessive moisture in the circuit.

A specialist intervention is required.

## 13 HYDRAULIC CONNECTIONS

### 13.1 Diameter of hydraulic and refrigerant connections

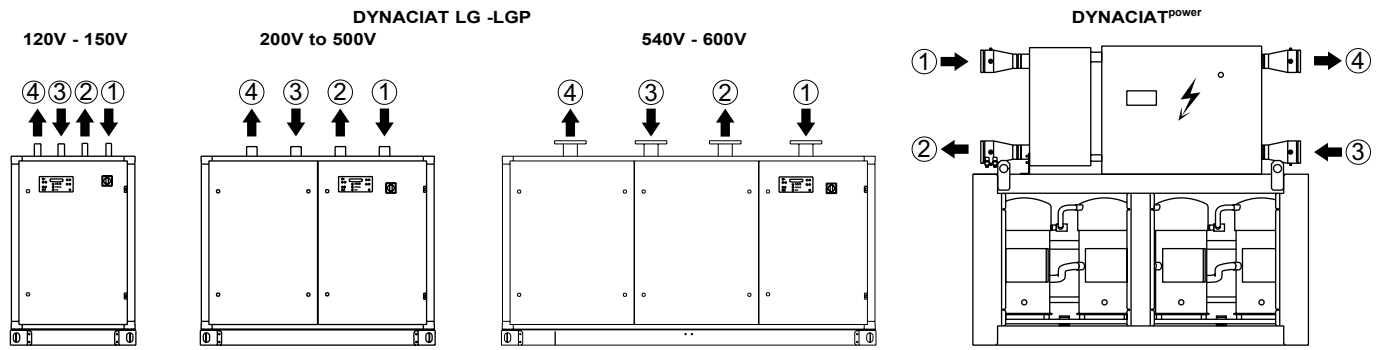

DYNACIAT		LG – LGP									
		120V	150V	200V	240V	300V	350V	400V	500V	540V	600V
Inlet / Outlet Chilled water	① ②	∅	G 1" 1/2				G 2"	G 2" 1/2	PN 16 DN 80 flanges		
Inlet / Outlet Cooling water	③ ④	∅	G 1" 1/2				G 2"	G 2" 1/2	PN 16 DN 80 flanges		

DYNACIAT <sup>power</sup>		LG – LGP											
		700V	800V	900V	1000V	1100V	1200V	1400V	1600V	1800V	2100V	2400V	
Inlet / Outlet Chilled water	① ②	∅	DN 100 PN 16 - VICTAULIC				DN 125 PN 16 - VICTAULIC				DN 150 PN 16 VICTAULIC		
Inlet / Outlet Cooling water	③ ④	∅	DN 100 PN 16 - VICTAULIC				DN 125 PN 16 - VICTAULIC				DN 150 PN 16 VICTAULIC		

These values may be assimilated for the diameters of the copper tubing for a max. developed length of 15 m and a max. gradient of 6 m.

Hydraulic connections must be made in accordance with the diagram delivered with the unit. This diagram shows the positions and dimensions of the water inlets and outlets on the exchangers.

Follow the requirements below when making these connections:

- Ensure the inlet and outlet pipes are connected in the direction shown on the unit.
- In order to meet the operating conditions (flow rates, pressure loss), a sizing calculation must be performed. The diameter of the pipes may therefore be different to that specified on the exchanger.
- The pipes and tubes should not transmit any axial or radial forces to the exchangers or any vibrations.
- The water used must be analysed and, if necessary, treated (we recommend contacting a qualified water treatment specialist).

The analysis will reveal whether the water is suitable for use with the various materials it will come into contact with and prevent the formation of electrolytic couples:

- 99.9% copper tubes brazed with copper and silver
- Threaded bronze couplings or flat steel flanges, depending on the unit model
- Plate heat exchangers and connections made of AISI 316 - 1.4401 stainless steel brazed with copper and silver
- The water circuit should have the least possible number of elbows and horizontal sections at different levels.
- Install shut-off valves near the water inlets and outlets in order to be able to isolate the exchangers.
- Install manual or automatic bleeder valves at circuit high point(s).
- The manual or automatic bleeder valves fitted on the machine are not intended to be used to bleed air from the rest of the water circuit.
- A static pressure of 1 bar must be maintained at all times (machine and pump off or on) on the pump intake.
- Install drain connections at all circuit low point(s).
- Fit all the accessories that are essential to all hydraulic circuits (balancing valves, expansion vessel, pressure relief

valve, thermometer pockets...).

- Insulate the pipes and tubes (after performing leak tests) in order to reduce heat losses and prevent damage from frost.
- Install heating elements on all pipes that could be exposed to freezing temperatures.
- The installer must provide the necessary systems for filling and draining the coolant.
- To keep the pressure in the coolant circuit below the intended operating pressure, avoid introducing static or dynamic pressure into the circuit.

#### IMPORTANT:

- To prevent any risk of fouling or damage to the plate heat exchangers (evaporator and condenser), it is essential to fit a strainer to the water inlets as close as possible to the exchangers and in a place which is easily accessible for disassembly and cleaning. The strainer should have a mesh of not more than 800 µm (see price option)
  - Flexible couplings must be used on the hydraulic pipework (evaporator and condenser)
- The system pipework must be secured to the wall of the building and must not place any additional load on the unit.
- Using untreated or incorrectly treated water may cause corrosion or erosion or the formation of scale, algae or sludge deposits. **CIAT** shall not be held liable for damage resulting from the use of untreated or incorrectly treated water or of seawater or brackish water.

**When the unit is used in heat pump function (DYNACIAT LGP), the maximum water return temperature of the system must be 55°C. Never series-connect the condenser with a high temperature water network (boiler). Doing so will result in damage.**

**NOTE:** The maximum operating pressure on the water side should be 10 bar (evaporator and condenser). The water flow sensor is supplied fitted to the unit. **Stopping the pumps will automatically cause the unit to stop to avoid any risk of freezing. The pump or pumps must be slaved to the refrigeration unit** (auxiliary operation switch of the pump to

be wired). If the hydraulic circuit is drained for a period of more than one month, fill the entire circuit with nitrogen to prevent any risk of corrosion.

**IMPORTANT:**

If antifreeze is not added to the circuit and the unit is not operated during periods of freezing weather, it is essential to drain the evaporator and the outside pipes.

**13.2 FLANGE/VICTAULIC adapter kit for DYNACIAT<sup>power</sup> (OPTION)**

The connections to the exchangers are the VICTAULIC type.

A FLANGE/VICTAULIC adapter kit can be supplied separately to be fitted on site by the installer to allow flange connection to the hydraulic circuit.

Two kits are available:

1) FLANGE/VICTAULIC adapter kit

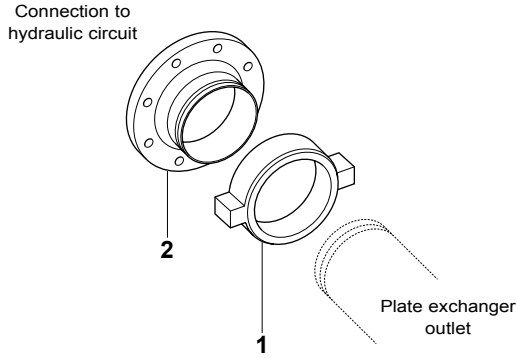

2) FLANGE/VICTAULIC adapter kit + flexible coupling

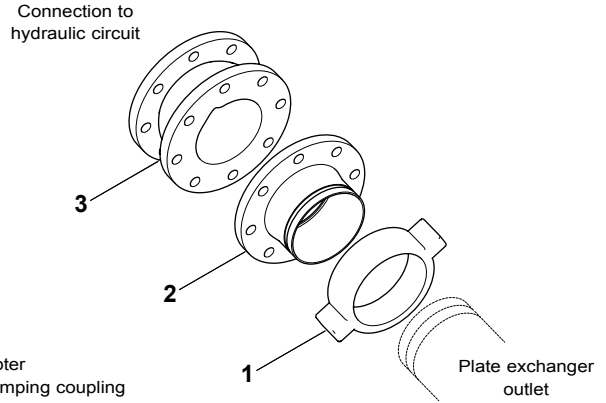

- 1 - Hose clamp
- 2 - Flange adapter
- 3 - Vibration damping coupling

**14 ANTI-FROST PROTECTION FOR THE INSTALLATION**

The table and the curves below indicate the minimum percentages of glycol with which the system must be provided depending on the freezing point.

**WARNING:** The glycol concentration must protect the fluid at least 6°C below the water outlet temperature specified for the evaporator to allow correct setting of the minimum pressure regulator at the evaporator.

**Glycol concentration required**

Volume concentration in %		0	10	20	30	40
Ethylene glycol	Freezing point °C	0	-4	-10	-18	-27
	Minimum water outlet °C	5	+3	-1	-7	-14
Propylene glycol	Freezing point °C	0	-4	-9	-16	-25
	Minimum water outlet °C	5	+4	+1	-4	-9

**Important:** The values are given for guidance only, according to standard characteristics of the MEG. These may vary depending on the MEG manufacturer, therefore it is important to refer to the manufacturer's data to ensure protection is provided to the required temperature.

For a glycol concentration higher than 40%, a special pump is required

**Graph of minimum freezing temperatures and use**

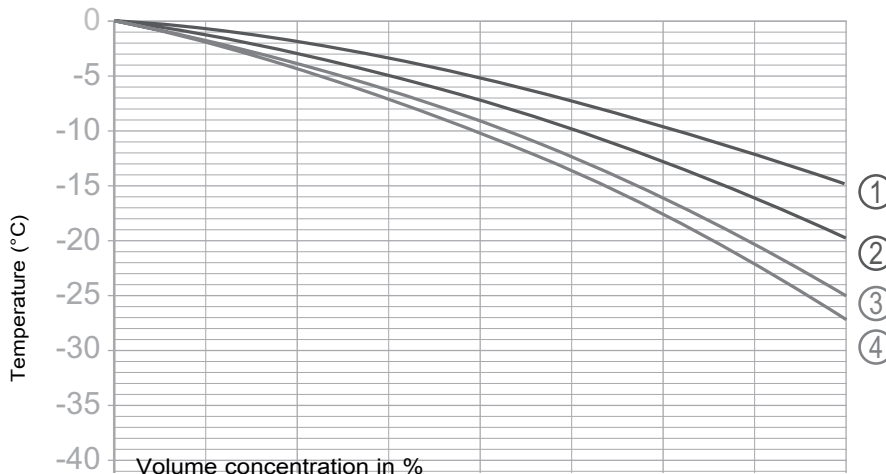

Minimum operating temperature  
 1 - Monopropylene glycol  
 2 - Monoethylene glycol

Freezing temperature  
 3 - Monopropylene glycol  
 4 - Monoethylene glycol



## 15 ELECTRICAL CONNECTIONS

### 15.1 Power connection

The units are designed in accordance with the requirements of European standard EN 60204-1.

**They comply with the requirements of the machinery and EMC directives.**

All wiring must be connected in accordance with the codes and regulations that apply to the installation site (e.g. NFC 15100 in France).

In all cases:

- Refer to the wiring diagram attached to the unit.
- Follow the electrical supply specifications indicated on the data plate.

The voltage must remain within the range indicated:

- Power circuit
  - 400 V (+10% / -10 %) - 3ph - 50 Hz + Earth
  - \* 230 V (+10 % / -10 %) - 3 ph - 50 Hz + Earth
- Control circuits :
  - Control circuit 1~50 Hz 230 V (transformer fitted as standard on the machine)

\* Installation according to French regulations

- Phase unbalance must not exceed 2% and 10% for voltage and current, respectively.

If any of the above requirements are not met, contact your power supplier immediately and make sure the unit is not turned on until the necessary corrective actions have been taken. Failure to do so will automatically void the **CIAT** warranty.

Wiring is to be sized by the installer to suit the characteristics

of the installation site and comply with applicable regulations. Once the size of the wires has been selected, the installer must determine any changes needed on site to facilitate connection.

- Wiring must be selected based on:
  - The maximum rated current (refer to the “Electrical specifications” section).
  - The distance between the unit and its power source.
  - The protection to be placed at the power source.
  - The neutral mode.
  - The electrical connections (refer to the wiring diagram provided with the unit).
- The electrical connections are to be made as follows:
  - Connection to the power circuit.
  - Connection of the protective conductor to the earth terminal.
  - Connection of the general fault reporting dry contact and the automatic operation control dry contact (where applicable).
    - Interlock the compressors with the accelerator pump.
- The external control must be connected using a potential-free (dry) contact.
  - The disconnect switch has a breaking capacity of:
    - 50 kA for DYNACIAT LG, LGP 120V to 600V,
    - 40.5 kA for DYNACIAT<sup>power</sup> LG and LGP 700V to 1200V,
    - 61.5 kA for DYNACIAT<sup>power</sup> LG and LGP 1400V to 2100V,
    - 70 kA for DYNACIAT<sup>power</sup> LG and LGP 2400V,

The unit is supplied by the upper right section of the electrical cabinet with an opening for routing the supply cables.

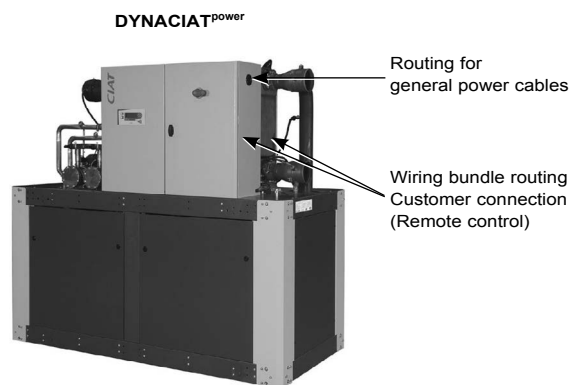

### 15.2 Customer connection for remote control functions.

Certain operating states can be wired directly to 1X terminal provided for this purpose:

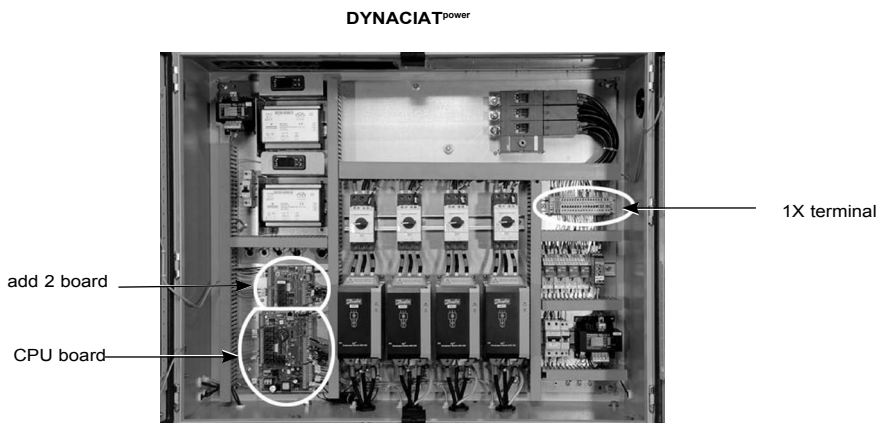

**General fault alarm:**

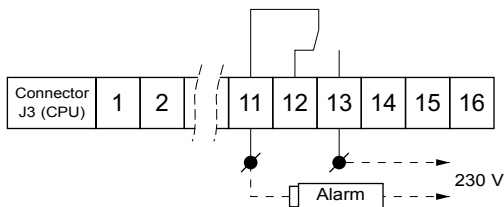

Remote control  
 Connect the unit's general fault reporting or alarm to the terminals on the unit's terminal block (see wiring diagram).  
 • Specifications for the output: 2 A at 250 V

**Automatic operation control:**

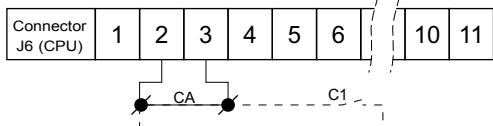

Remove shunt «CA» from between the terminals on the unit terminal block (see wiring diagram) and connect a «C1» contact to them (good quality polarity-free contact).  
 • Contact open → unit stopped  
 • Contact closed → unit authorised to operate  
 • Specifications for the input: 24 V - 15 mA

**Display of the operating state of pump No. 1**

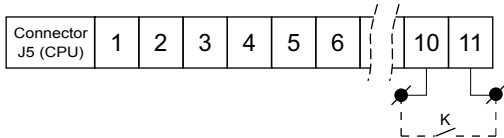

- Contact open → Pump stopped
- Contact closed → Pump operating
- Specifications for the input: 24 V - 15 mA

Other connections can be made to the CPU CONNECT2 board.

**Water pump control**

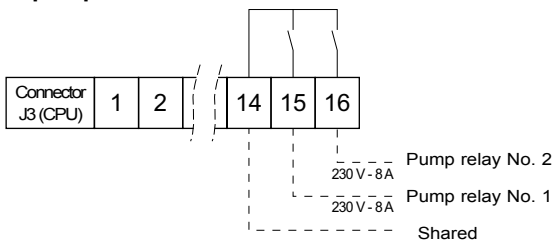

Connect the supply to the pump relays between the terminals of the connector on the main board.  
 • Specifications for the output: 2 A at 250 V

**Setpoint 1/setpoint 2 selector control**

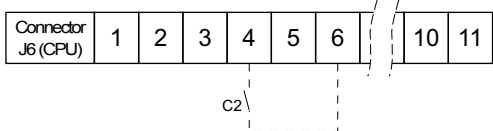

Connect a «C2» contact to the connector on the CPU board (good quality polarity-free contact)  
 • Contact open → set point 1  
 • Contact closed → set point 2  
 • Specifications for the input: 24 V - 15 mA

**16 CONTROL AND SAFETY DEVICES**

**16.1 Electronic control and display module**

All units in the **DYNACIAT** and **DYNACIAT<sup>POWER</sup>** range and its derivatives are fitted with a CONNECT2 microprocessor-controlled electronic control and display module.  
 The electronic module controls the operation of the

**Display for operation at full power (if P111 = max P)**

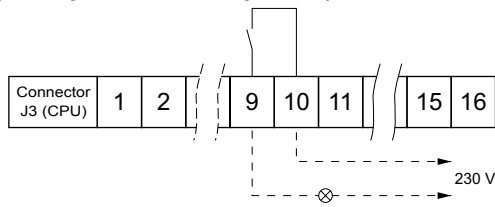

Connect the signalling of the unit operating at max. capacity to terminals 1 and 2 of the connector on the CPU board.  
 • Specifications for the output: 2 A at 250 V

**«Load shedding» function control**

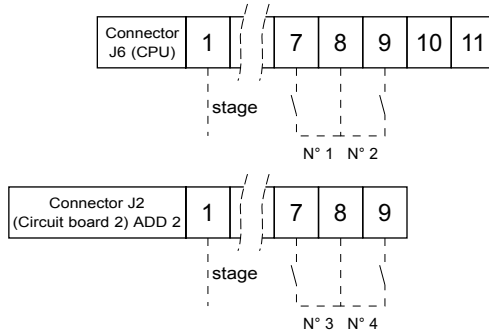

Connect 1 to 4 contacts to the terminals of the connector of the CPU board according to the number of the compressors to be shed. 1 contact per compressor (contact free of any polarity and of good quality).  
 • Contact open → normal operation  
 • Contact closed → compressor load shedding.  
 • Specifications for the input: 24 V - 15 mA

**NOTE:**

- Connection to be made on-site by the customer,
- Precautions for connection. See manual for the regulator and the electrical diagram of the unit.

**Communication**

- In local mode, a control and display console is used to run an instant check on the unit; it enables the user to communicate with the microprocessor, to configure the unit and to adjust the setpoints.
- Electronic remote control (option) :  
 Installed in the mechanical room, this will be connected to the unit by a pair of telephone-type wires (max. distance 1000 m). Description of functions and connection: see CONNECT2 manual.
- Relay board(s) (option):  
 This board is installed in a cabinet in the mechanical room and can remotely report on all the unit's operating statuses and faults by providing potential-free make contacts. The board will be connected to the unit by a pair of telephone-type wires (max. distance 1,000 m).

Description of functions and connection: see CONNECT2 manual.

- Communication with centralised technical management (option).
- See possibility in CONNECT2 manual.

compressors. Thus, depending on the difference between the cold water (or hot water) return temperature and the setpoint temperature, the electronic module will activate or deactivate the compressors in series.

In a standard configuration of the unit, the cold water or hot water regulation sensor is placed on the evaporator water return (chilled water production use) or condenser (heat pump use).

## 16.2 Main functions

- Control of hot water temperature:
    - Chilled-water evaporator.
    - Hot water condenser.
  - Three types of control are possible:
    - Difference with water return.
    - Water outlet PID temperature.
    - Control according to the outside temperature
- The units are fitted in standard configuration with a control on the chilled water return. For PID water outlet temperature control, refer to the Connect2 control manual.
- Operating settings check.
  - Fault diagnosis.
  - Fault storage in the event of a power failure.
  - Management and automatic equalisation of compressor operating time (multi-compressors).
  - Remote control facility (ON/OFF, adjustment of set temperature, operating status, general fault) (OPTION).
  - Remote control reporting on operating status and faults using an interface module (OPTION).

**For a detailed description of all these functions refer to the CONNECT2 user manual.**

## 16.3 Safety device management

All of the unit's safety devices are managed by the electronic circuit board in the regulator. If a safety device is triggered and stops the unit, trace the fault, reset the safety device if necessary, then clear the fault with the «RESET» button on the CONNECT2 console.

The unit will restart when the minimum time required by the short-cycle protection elapses.

To ascertain the setting values of the different safety devices and the fault clearance procedures, refer to the CONNECT2 regulator instructions.

### ➤ Low pressure control

Each unit includes one low pressure sensor per refrigerating circuit as standard. This sensor enables the user to display the LP value and enables the electronic module to provide a safety function by ensuring that the LP value does not fall below the threshold parameter in the regulator.

### ➤ High pressure control

- High pressure switch

Each refrigerant circuit is fitted with a high pressure switch. The HP safety pressure switch is the safety accessory of the unit in operation. It will be determined by the refrigerant type. In this way, when the HP value exceeds the preset value of the pressure switch, power to the compressor(s) in the refrigerant circuit concerned is cut off and the fault is indicated by an LED on the regulator console.

The HP pressure switches are reset manually, thus any fault will be cleared by resetting the pressure switch and by pressing the RESET button on the console.

**N.B.:** Certain devices have two pressure switches per circuit (connected in series only).

- High pressure sensor

Each unit includes one high pressure sensor per refrigerating circuit as a standard item. This sensor enables the user to display the HP value and enables the electronic module to perform two functions: regulation of the unit by acting on the fans and safety.

### ➤ Evaporator frost protection

The evaporator is protected against the risk of frost by two probes:

- Chilled water evaporator outlet sensor

Each evaporator is fitted with a frost protection sensor (located on the chilled water outlet) which monitors the temperature of the fluid to be cooled. If this temperature falls below the set value in the regulator, power to the compressor(s) in the refrigerant circuit concerned is cut off and the fault is indicated by an LED on the regulator console. This probe acts as a safety device and must therefore never be moved by the customer.

- Evaporator inlet freon sensor or circuit 1 or 2 pressure sensor (LP) (DYNACIAT power 1400V to 2400V)

This sensor monitors the temperature of the refrigerant at the evaporator inlet. If this temperature falls below the set value in the regulator, power to the compressor(s) in the refrigerant circuit concerned is cut off and the fault is indicated by an LED on the regulator console.

### ➤ Evaporator water circulation controller

Every unit is fitted with a water circulation control device as standard. Thus, if the water flow is insufficient, the power supply to the compressor(s) is cut and an LED indicates the fault on the regulator console.

### ➤ Internal compressor protection

Every model in the LG, LGP range is protected against overheating of the electric motor and high discharge temperatures.

The DYNACIAT<sup>power</sup> LG, LGP 700V to 2400V are fitted with compressors with internal protection that protects against loss of phase and inverted phases.

On all the models, a phase controller can be added if required by the customer (option)

### ➤ Discharge sensor

Each unit includes one discharge sensor per refrigerating circuit as standard. This sensor located on the discharge piping makes it possible for the user to view the to provide a safety function.

If the discharge temperature exceeds the maximum temperature threshold set in the regulator, the power supply to the compressor(s) for the refrigeration circuit concerned is cut and the fault is indicated by an LED on the regulator console.

### ➤ Protection against overpressure

Each refrigeration circuit in each unit is protected against the risk of overpressure resulting from fire.

- Fire valves

- The fire valve(s) protect(s) the LP and HP circuits against overpressure coming from an increase in the external temperature, when the unit is off. (e.g. external fire)
- This fire valve is not seen as a safety accessory under section 2.11 of annex 1 of the pressure equipment directive.

- Acceptable pressures (PS) on the LP side

- The value of the LP (indicated on the manufacturer's plate) reflects the unit situation when off. This value is given based upon the pressure/temperature ratio, with an external temperature of 50 °C depending on the unit. These temperatures relate to the least favourable situation encountered by the unit, except external fires

The pipes and ducts on the LP side are dimensioned for the maximum acceptable pressure.

The LP value is linked to the unit concerned and cannot be exceeded.

### 16.4 DYNACIAT LG, LGP 120V to 500V 2-way valve kit

If municipal wastewater is used to cool the condenser, we recommend installing the two-way valve kit so as to be able to set the condensing pressure to a value that will ensure correct operation of the unit and save on cooling water. The kit will be placed at the outflow of the condenser to ensure that the exchanger is always being refilled.

The kit consists of:

- A two-way valve
- A servomotor
- A circuit-breaker
- A 230V/24V transformer + rail and mounting bolts
- A set of assembly instructions

The threshold values of the HP that correspond respectively to the 0 and 10V signals can be configured via the CONNECT2 controller.

These thresholds correspond to the opening start and the complete opening of the two-way valve.

**• Advantages:**

The advantages of using this kit are twofold:

- Elimination of «cold start» problems
- Reduction in water consumption by adjusting the value of the condensation temperature value required.

In order to minimise the water consumption of the unit, it is recommended that the threshold of the HP corresponding to the 10V signal is set to a level which offers the best compromise between the absorbed power of the machine and the water consumption. The higher this value is, the greater the absorbed power but the lower the water consumption

### 16.5 Phase controller kit

The phase monitor kit performs the following functions:

- Controls the direction of rotation of each phase
- Detects the absence of one or more phases
- Monitors for overvoltage or undervoltage

The kit consists of:

- The network monitor relay + rail and mounting screw
- Connection cables
- A set of assembly instructions

### 16.6 Location of the safety sensors and devices

DYNACIAT LG - LGP 120V to 500V with thermostatic expansion valves

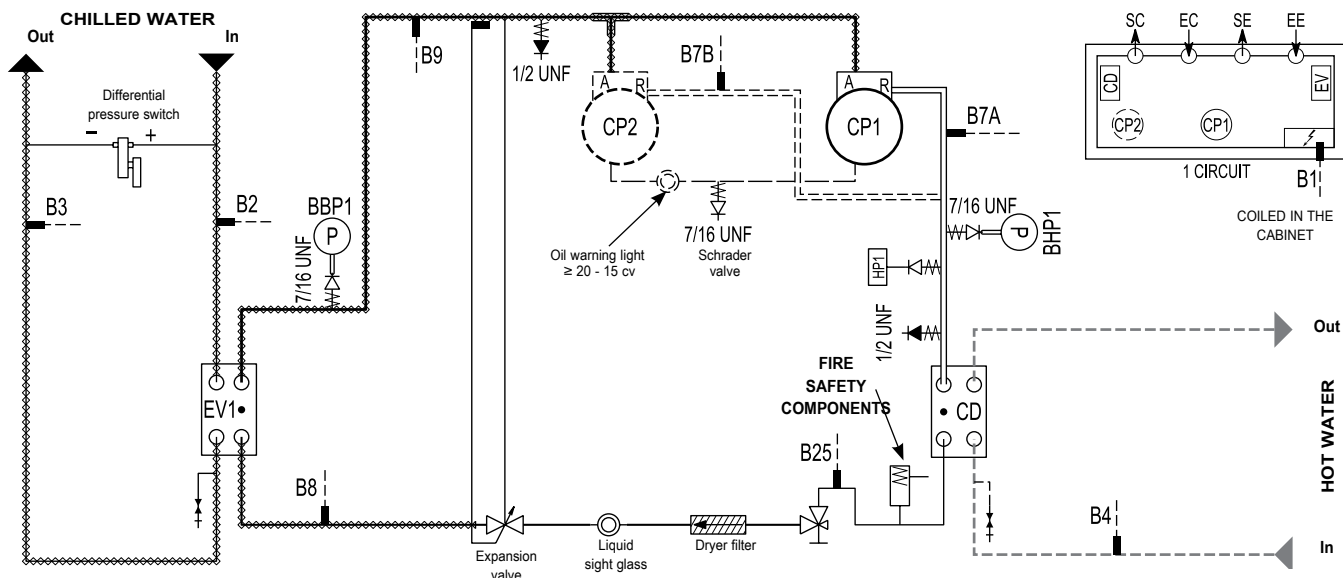

**SC:** Condenser water outlet

**EC:** Condenser water inlet

**SE:** Evaporator water outlet

**EE:** Evaporator water inlet

**CIRCUIT 1**

**B1:** Outdoor temperature sensor

**B2:** Chilled water inlet sensor

**B3:** Exchanger 1 chilled water outlet sensor  
(Only with DYNACIAT)

**B4:** Exchanger ambient temperature / hot water sensor

**B7A:** Stage 1, circuit 1 discharge sensor

**B7B:** Stage 2, circuit 1 discharge sensor

**B8:** Exchanger 1 refrigerant / frost protection sensor

**B9:** Circuit 1 suction sensor

**B25:** Circuit 1 refrigerant / liquid sensor

**DYNACIAT LG - LGP 540V - 600V with thermostatic expansion valves**

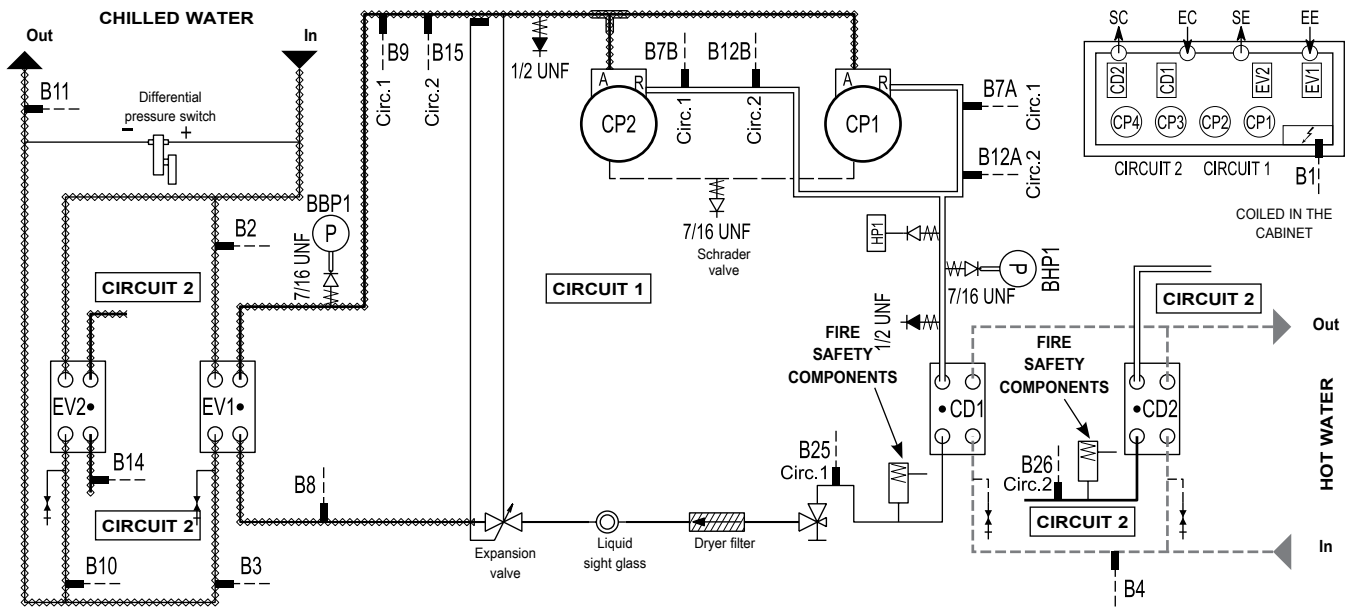

**N.B.:** DYNACIAT LG 540V and 600V = 2 identical refrigerant circuits

**DYNACIAT<sup>power</sup> 700V to 1600V with thermostatic expansion valves**

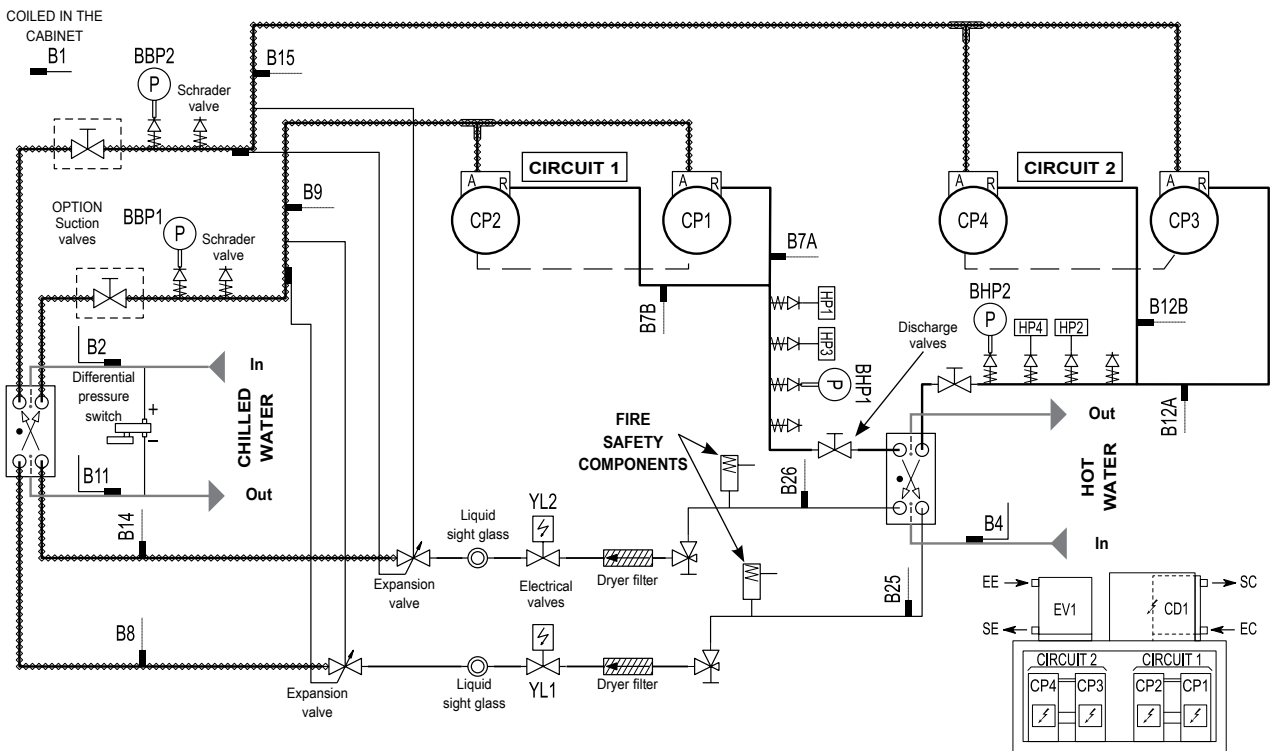

**SC:** Condenser water outlet

**EC:** Condenser water inlet

**CIRCUIT 1**

**B1:** Outdoor temperature sensor

**B2:** Chilled water inlet sensor

**B3:** Exchanger 1 chilled water outlet sensor  
(Only with DYNACIAT)

**B4:** Exchanger ambient temperature / hot water sensor

**B7A:** Stage 1, circuit 1 discharge sensor

**B7B:** Stage 2, circuit 1 discharge sensor

**B8:** Exchanger 1 refrigerant / frost protection sensor

**B9:** Circuit 1 suction sensor

**B25:** Circuit 1 refrigerant / liquid sensor

**SE:** Evaporator water outlet

**EE:** Evaporator water inlet

**CIRCUIT 2**

**B10:** Exchanger 2 chilled water outlet sensor  
(Only with DYNACIAT)

**B11:** Chilled water outlet manifold sensor

**B12A:** Stage 1, circuit 2 discharge sensor

**B12B:** Stage 2, circuit 2 discharge sensor

**B14:** Exchanger 2 refrigerant / frost protection sensor

**B15:** Circuit 2 suction sensor

**B26:** Circuit 2 refrigerant / liquid sensor



## DYNACIAT<sup>power</sup> 700V to 1600V with electronic expansion valves

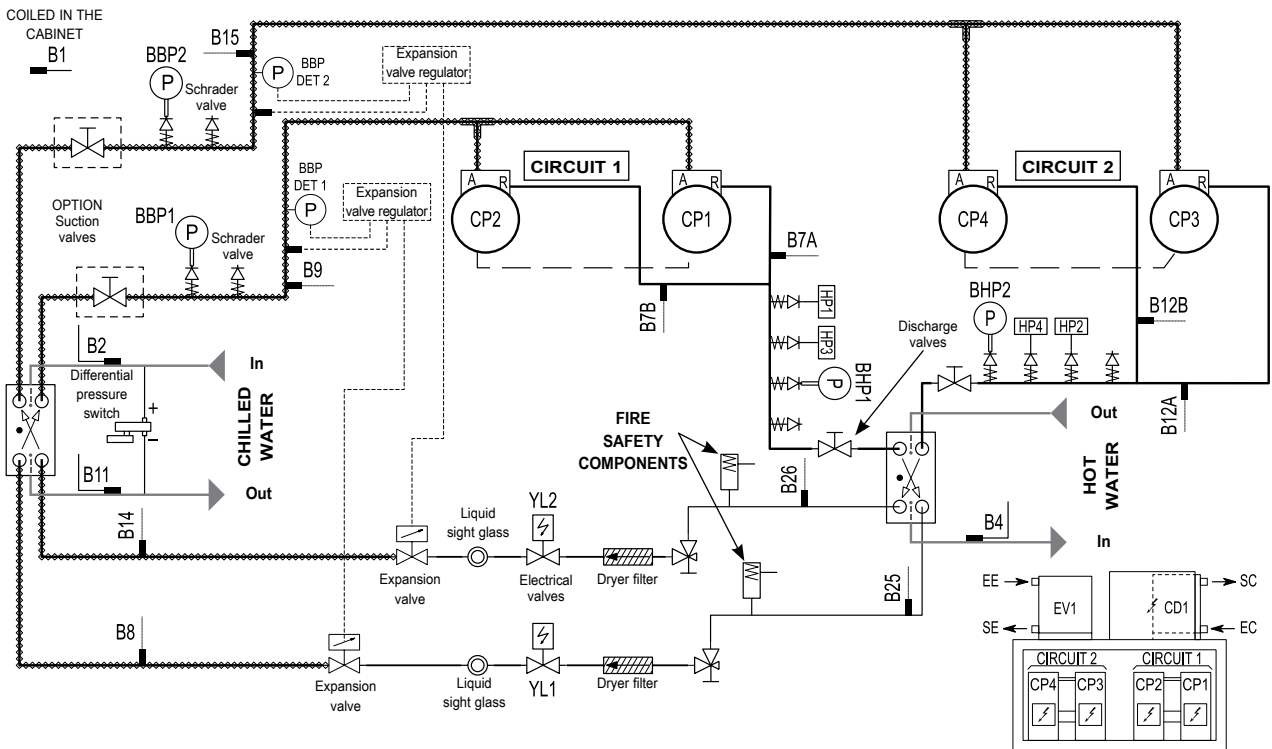

## DYNACIAT<sup>power</sup> 1800V to 2400V with electronic expansion valves

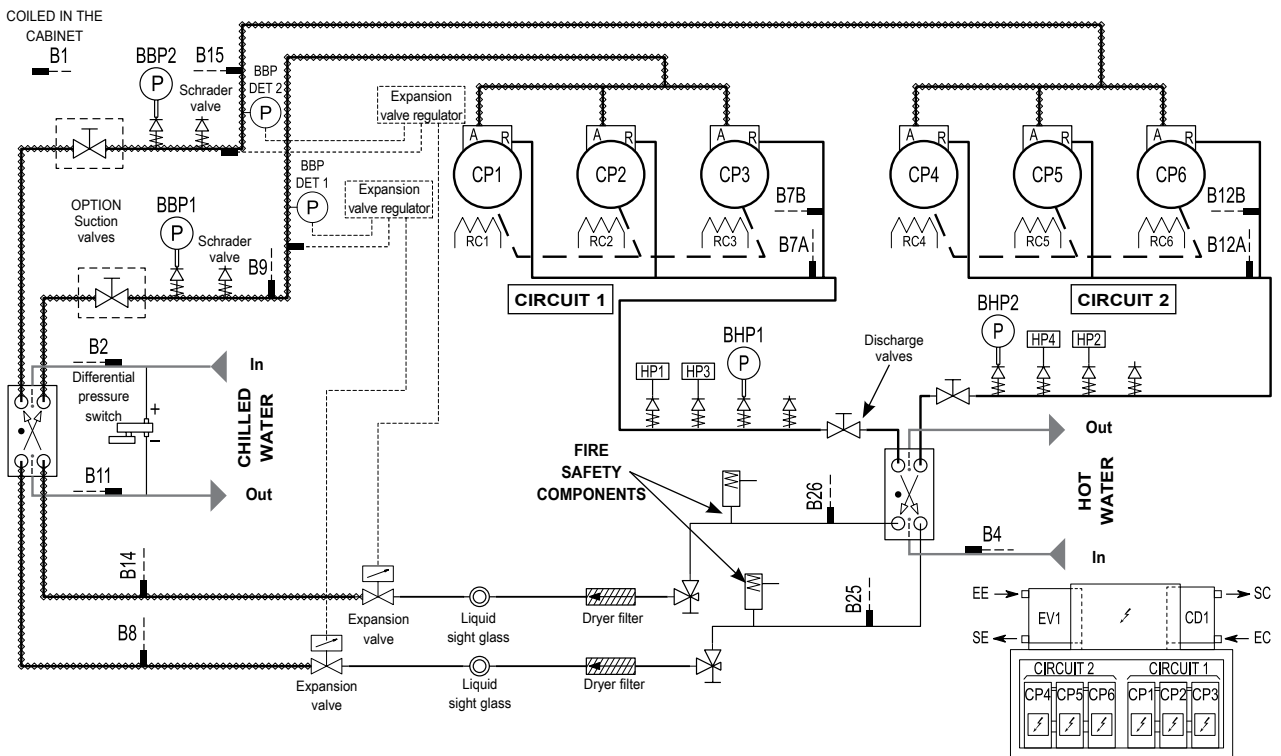

**SC:** Condenser water outlet

**EC:** Condenser water inlet

### CIRCUIT 1

**B1:** Outdoor temperature sensor

**B2:** Chilled water inlet sensor

**B3:** Exchanger 1 chilled water outlet sensor  
(Only with DYNACIAT)

**B4:** Exchanger ambient temperature / hot water sensor

**B7A:** Stage 1, circuit 1 discharge sensor

**B7B:** Stage 2, circuit 1 discharge sensor

**B8:** Exchanger 1 refrigerant / frost protection sensor

**B9:** Circuit 1 suction sensor

**B25:** Circuit 1 refrigerant / liquid sensor

**SE:** Evaporator water outlet

**EE:** Evaporator water inlet

### CIRCUIT 2

**B10:** Exchanger 2 chilled water outlet sensor  
(Only with DYNACIAT)

**B11:** Chilled water outlet manifold sensor

**B12A:** Stage 1, circuit 2 discharge sensor

**B12B:** Stage 2, circuit 2 discharge sensor

**B14:** Exchanger 2 refrigerant / frost protection sensor

**B15:** Circuit 2 suction sensor

**B26:** Circuit 2 refrigerant / liquid sensor

## 16.7 Adjusting the control and safety devices

Units	Function	Electrical symbol	Settings
Outdoor sensor	Adjust the setpoint according to the outdoor temperature	B1	CONNECT2 controller
Chilled water inlet sensor	Regulation of the unit on the water return	B2	
Circuit 1, circuit 2 chilled water exchanger outlet sensor (Only with DYNACIAT)	Regulation of the unit if regulation is on the water outlet (only for circuit 1 sensor) Frost protection of the evaporator	B3, B10	
Chilled water outlet manifold sensor	Regulation of the unit if regulation is on the water outlet	B11	
Hot water inlet sensor	Unit control in hot operation	B4	
Discharge sensor circuit 1, circuit 2	Compressor protection	Circ. 1 : B7A, B7B Circ. 2 : B12A, B12B	
Evaporator inlet freon sensor circuit 1 and circuit 2	Frost protection of the evaporator	Circ. 1 : B8 Circ. 2 : B14	CONNECT2 regulator
High Pressure Switch circuit 1 and circuit 2	Compressor safety devices	Circ. 1 : HP1, HP3 Circ. 2 : HP2, HP4	
Low Pressure sensor circuit 1 and circuit 2	Low pressure value control Fluid leak detection	Circ. 1 : BBP1 Circ. 2 : BBP2	
High Pressure sensor circuit 1 and circuit 2	High pressure value control Controlling the unit by high pressure Condensing pressure control	Circ. 1 : BHP1 Circ. 2 : BHP2	

## 17 COMMISSIONING

**Pre-commissioning checks: Always read this manual in full before attempting to commission the system.**

Comply with applicable national regulations during testing and installation.

Before commissioning the system, carry out the following checks:

- Compare the complete system against the refrigeration and wiring diagrams
- Make sure that all components are as specified on the drawings
- Make sure that no documents and safety devices required by applicable European standards are missing
- Make sure that there is sufficient clearance around the system for maintenance and emergency purposes
- Check the assembled couplings
- Check the quality of the welds and seals and check for any refrigerant leaks
- Make sure that all mechanical guards are in place and functional
- Consider the problems of specific noise generated by the system.
- After opening the water circuit valves, make sure that water is flowing in the cooler while the pump is running

**The hydraulic circuit must be bled before the machine is turned on.**

For this operation, the pump(s) must have been started up.

To make this work without engaging the compressors, all of the machines are delivered with the setting 'compressor on authorisation' set to 'NO'.

The operation can therefore be carried out with no risk of starting up the compressors by putting the machine control to the 'ON' position.

Once the hydraulic circuit has been bled, the machine is turned on by switching the compressor on setting to 'YES', which authorises start up.

List of settings according to type of regulator:

- P230 Stage 1, circuit 1 'on' authorisation
- P231 Stage 2, circuit 1 'on' authorisation
- P232 Stage 1, circuit 2 'on' authorisation
- P233 Stage 2, circuit 2 'on' authorisation

- P235 Electric stage 1 'on' authorisation (Unit with Electric heater module)
- P236 Electric stage 2 'on' authorisation (Unit with Electric heater module)
- P237 Electric stage 3 'on' authorisation (Unit with Electric heater module)
- P238 Electric stage 4 'on' authorisation (Unit with Electric heater module)
- Check the operation of the circulation controller
- Check for loose clamps on all pipes
- Check for loose electrical connections
- 6 hours before using the device, turn on the resistors of the compressor casing.

After 6 hours, touch the casings to make sure that the heaters are operating correctly (they should be warm)

- Make sure current is supplied to the general connection and that the voltage supplied remains within the acceptable limits (+10% to -10% compared to the rated voltage)

**FLEXIBLE COUPLINGS MUST BE USED ON THE HYDRAULIC PIPEWORK (EVAPORATOR AND CONDENSER).**

### 17.1 Startup and commissioning

The system must be started and commissioned by a qualified technician.

- The system must be charged with refrigerant and water flowing in the exchangers when it is turned on and tested.
- Power up the main board

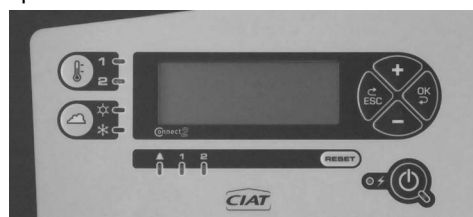

- Check that the machine is configured for local control (regulator selection)
- Select the operating mode using the  button (chilled or hot water operation)

- Enter the setpoints for:

Chilled water



Hot water



- Start the unit by pressing the on/off button
- The internal safety devices are now activated. If one of these safety devices is triggered, trace the fault, reset the safety device if necessary and press the RESET button on the console to clear the fault.
- The unit can only be started after 2 minutes (time required to scan and enable all the safety devices). The control stages should operate in cascade mode based on the demand.

**Use either of the following to turn off the unit in non-emergency situations:**

- the ON/OFF button on the console
- a dry contact on the automatic operation control.

**Do not use the main switch as the electrical panel must remain live (frost protection, crankcase resistor).**

**NOTE:**

The DYNACIAT LG 120V to 600V and the DYNACIAT<sup>power</sup> are machines that operate with R410A. It is essential that technicians use equipment which is compatible with R410A with a working pressure which is approximately 1.5 times higher than that of units using R407C

**17.2 Essential points to check**

**Compressors:**

Check that each compressor is rotating in the correct direction. The discharge temperature should rise quickly and the high pressure should rise and the low pressure should drop. If it is rotating in the wrong direction, the electric power supply is incorrectly wired (reversed phases). To resume the correct direction of rotation, it is necessary to swap two supply phases

- Check the discharge temperature of the compressor(s) using a contact sensor.
- Check the input current; it should be normal.
- Check all safety devices to make sure they operate correctly.

**Hydraulic:**

As the exact total drop in system pressure is not known at commissioning, adjust the flow of water with the control valve until the desired nominal rate is obtained. By causing the pressure in the water system to drop, this control valve aligns the system pressure/flow curve with that of the pump so that the nominal flow rate corresponding to the desired operating point is obtained.

The pressure drop in the plate exchanger (read using the gauge placed on the plate heat exchanger inlet and outlet) is the reference to be used to check and adjust the nominal flow rate of the system.

Follow the procedure described below:

- Open the control valve completely.
- Let the pump run for two hours to flush out any solid particles in the circuit.
- Read the pressure drop in the plate heat exchanger when the pump is started and 2 hours later
  - If the pressure drop has decreased this means that the screen filter is clogged; it must be removed and cleaned
  - Repeat until the clogging of the filter is removed.
- Once the circuit has been flushed of all contaminants, read the drop in pressure in the plate heat exchanger and compare it to the theoretical pressure drop selected.

If the reading is higher than the theoretical value, the flow rate is too high. In other words, the pump is delivering too much flow for the system pressure drop. Close the control

valve one complete turn and read the pressure drop. Continue by gradually closing the valve until the nominal flow rate for the desired operating point is obtained. However, if the system pressure drops far below the available static pressure delivered by the pump, the resulting water flow rate will be low and the difference in temperature between the exchanger inlet and outlet will be higher. This is why pressure drops must be minimised.

**Refrigerant charge:**

The LG and LGP units are shipped with an exact charge of refrigerant. To make sure that the unit is filled with the correct charge of refrigerant, perform the following checks circuit by circuit with the system running at full capacity:

- Check the overheating value which must be between 6 and 9 °C depending on the type of unit.
- In air conditioning mode only, check the actual subcooling value at the condenser outlet. It must be between 5 and 8 °C depending on the type of unit.
- Check there are no bubbles in the liquid sight glass.

If the charge is too low, large bubbles will appear in the liquid sight glass, the suction pressure will drop and overheating on the compressor inlets will be high. Locate the leak, completely drain the refrigerant charge using a recovery machine, and fill the unit with a new charge. Repair the leak, pressure test the unit (do not exceed the maximum service pressure on the low pressure end) then refill the unit. The refrigerant must be liquid and charged via the liquid charging valve. The amounts of refrigerant indicated on the data plate must be added to each circuit in the unit. Repeat these steps if the subcooling temperature is below the specified values.

**N.B:**

An excessively low suction pressure or an excessively high condensation pressure may sometimes be read when commissioning the unit. These problems may be caused by a number of possibilities. Refer to the Troubleshooting section for more information.

→ **Case of operation with negative temperatures**

- To guarantee operation of the unit, it is essential to:
  - adjust the regulator's safety parameters for the operating temperature
  - adapt the settings of the thermostatic expansion valve to have overheating at + 7 °C
  - adjust the refrigerant charge, checking that the subcooling values are between 5 and 8 °C

## 18 TECHNICAL AND ELECTRICAL SPECIFICATIONS

DYNACIAT LG - LGP		120V	150V	200V	240V	300V	350V	400V	500V	540V	600V
Net cooling capacity ①	kW	34.50	45.30	61.10	68.60	90.90	104.70	118.90	146.501	158.90	181.90
Net absorbed power ③	kW	8,00	10,30	13,90	16.20	20.30	23.60	26.90	33.80	36.10	40.10
Net EER efficiency ④		4.29	4.40	4.40	4.23	4.48	4.43	4.42	4.33	4.40	4.53
Net ESEER efficiency ④		4.63	4.69	5.23	4.99	4.97	4.98	5.02	4.80	4.99	5.06
Net heating capacity ②	kW	40.50	53.40	71.50	80.60	107.00	122.40	140.00	173.00	187.00	213.30
Net absorbed power ③	kW	10.10	12.90	17.70	20.30	25.30	29.10	33.20	41.40	45.10	50.20
EER efficiency ④		4.02	4.13	4.04	3.98	4.22	4.20	4.21	4.17	4.13	4.25
Sound power level ⑤	dB(A)	67.0	70.0	69.0	70.0	73.0	74.0	75.0	76.0	75.0	76.0
Compressor											
Type		Hermetic SCROLL (2900 rpm)									
Quantity		1		2						4	
Start-up mode		Direct in line in series									
Refrigerant oil type		POE 3MAF (32CST)									
Oil capacity	l. (circ. 1)	3.25	4.14	6.50	6.50	8.28	8.84	9.76	11.24	8.28	8.28
	l. (circ. 2)		-	-	-	-	-	-	-	6.50	8.28
Number of refrigerating circuits		1						2		2	
Refrigerant		R410A (GWP = 2088)									
Refrigerant charge (1 circ.) ou (circ.1 and circ. 2)	kg	3.3	3.8	6.8	7.1	9.9	11	13.7	16.1	7.3 + 9.5	9.9 + 9.9
CO2 equivalent tonne	tCO2Eq	6.89	7.93	14.19	14.82	20.67	22.96	28.60	33.61	35.07	41.34
Power control	Stages	1		2			3		2	4	
	%	100-0		100-50-0			100-57-43-0	100-63-37-0	100-50-0	100-72-50-22-0	100-75-50-25-0
Evaporator											
Number and type		1 brazed plate heat exchanger									
Water content	l	2.7	3.6	4.8	5.3	9.9	11.3	12.8	15.7	15.2	19.8
Min / max water outlet temperature	°C	-10 °C / +18 °C									
Minimum/maximum water flow rate	m³/h	3.5/11.2	4.8/14.6	6.2/19.8	7.0/22.2	9.5/29.2	10.9/34.0	12.4/38.4	15.2/47.5	16.4/51.1	19.1/58.4
Water connections	Ø	G 1" 1/2		G 1"1/2		G 2"		G 2"1/2		DN 80 PN 16	
Minimum system diameter	Ø	DN 50				DN 65				DN 80	
Max service pressure	bar	10 bar water side									
Water cooled condenser											
Number and type		1 brazed plate heat exchanger									
Water content	l	3.0	4.1	5.1	5.8	8.0	9.4	11.1	15.2	13.8	16.0
Min / max water outlet temperature	°C	+30 °C / +55 °C									
Minimum/maximum water flow rate	m³/h	3.1/8.5	4.1/11.1	5.4/15.1	6.1/17.0	8.2/22.3	9.4/26.0	10.7/29.4	13.1/35.0	14.3/39.1	16.3/44.6
Water connections	Ø	G 1"1/2				G 2"		G 2"1/2		DN 80 PN 16	
Max service pressure	bar	10 bar water side									
Dimensions and weight											
Storage temperature	°C	See section 1 Introduction									
Min water volume	l.	226	299	197	222	292	286	279	454	217	274
Operating height ⑥	mm	1201									
Length	mm	798				1492				2380	
Depth	mm	883									
Weight (empty)	kg	230	300	385	390	590	620	665	735	930	1125
Weight in working order	kg	240	312	400	406	617	650	703	780	990	1190
Electrical supply											
Compressor voltage	ph/Hz/V	3 / 50 Hz / 400 V (+10 % / -10 %)									
Machine protection rating		IP 22									
Electrics box protection rating		IP 22									
Max. rated current	A	23.2	30.2	42.2	46.2	60.2	66.2	76.0	91.8	106.2	120.2
Starting current	A	137.0	174.0	139.0	160.0	204.0	255.0	302.0	317.8	250.0	264.0
Starting current, Soft Start option	A	70.0	60.0	76.0	93.0	90.0	167.0	194.0	210.0	136.0	150.0
Breaking capacity	kA	50									
Max. wire cross-section	mm²	50						95			
Control circuit voltage	ph/Hz/V	1 / 50Hz / 230V (+10 % / -10 %) - Transformer assembled									

① Cooling capacities for chilled water temperature +12°C / +7°C and condenser hot water temperature +30°C / +35°C  
 ② Heating capacities for hot water temperature +40°C / +45°C and condenser hot water temperature +12°C / +7°C

③ Compressor net power input  
 ④ COP performance, EER or ESEER efficiency values  
 ⑤ LW: Overall power level, as per ISO standard 3744  
 ⑥ Height excluding handling mounts

DYNACIAT <sup>power</sup> LG - LGP		700V	800V	900V	1000V	1100V	1200V	1400V	1600V	1800V	2100V	2400V		
Cooling capacity ①	kW	217	251	288	327	356	385	443	499	582	657	713		
Compressor power input ②	kW	48.20	55.20	64.20	73.00	79.20	85.60	97.40	110.40	125.00	146.00	168.00		
EER / ESEER efficiency ③		4.50/5.53	4.55/5.59	4.48/5.48	4.48/5.38	4.49/5.44	4.50/5.47	4.55/5.44	4.52/5.34	4.66/5.64	4.51/5.48	4.24/5.34		
Sound power level ④	Lw / Lp Standard	dB(A)		89/57	90/58		89/57	90/58	91/59	95/63	96/64	93/61	95/63	97/65
	Lw / Lp Low Noise	dB(A)		84/52	85/53		86/54	87/55	88/56	90/58	91/59	89/57	90/58	91/59
	Lw / Lp Xtra Low Noise	dB(A)		79/47	80/48		81/49	82/50	85/53	86/54	85/53	86/54	87/55	87/55
<b>Compressor</b>														
Type	Hermetic SCROLL (2900 rpm)													
Quantity	4						6							
Start-up mode	Direct in line in series													
Refrigerant oil type	POE 160SZ						POE 3MAF							
Oil capacity (circ.1 + circ. 2)	l.	6.7 + 6.7				7.2 + 7.2		6.3 + 6.3		6.3 + 6.3 + 6.3				
Number of refrigerating circuits	2													
Refrigerant	R410A (GWP = 2088)													
Refrigerant charge (circ.1 + circ. 2)	Kg	13.5 + 14	15.5 + 15	16.4 + 16.4	17 + 17.2	19.7 + 19.7	21.3 + 21.3	21.5 + 21	23 + 22	31 + 31	33 + 34	34 + 34		
CO2 equivalent tonne	tCO2Eq	57.42	63.68	68.49	71.41	82.27	88.95	88.74	93.96	129.46	139.90	141.98		
Power control	Stages	6	4	6	4	6	4	6	4	6	8	6		
	%	100-78-71-50-28-21-0	100-75-50-25-0	100-78-71-50-28-21-0	100-75-50-25-0	100-78-71-50-28-21-0	100-75-50-25-0	100-78-71-50-28-21-0	700-75-50-25-0	100-83-66-50-33-16-0	100-84-66-48-36-30-18-15-0	100-83-66-50-33-16-0		
<b>Évaporator</b>														
Number and type	1 brazed plate heat exchanger													
Water content	l	20	23	26	29	32	37	50	57	64	77	77		
Min / max water outlet temperature	°C	-12 °C / +18 °C												
Minimum/maximum water flow rate	m³/h	22/70	26/81	29/82	33/105	35/113	38/124	44/137	51/151	61/150	68/150	74/150		
Water connections	Ø	VICTAULIC DN 100			VICTAULIC DN 125				VICTAULIC DN 150					
Minimum system	Ø	DN 100			DN 125				DN 150					
Max service pressure	bar	10 bar water side												
<b>Water cooled condenser</b>														
Number and type	1 brazed plate heat exchanger													
Water content	l	23	26	29	32	37	40	55	61	73	77	77		
Min / max water outlet temperature	°C	-0 / +18 °C												
Minimum/maximum water flow rate	m³/h	19/64	22/74	25/84	28/95	31/103	33/112	38/129	43/143	52/150	59/150	66/153		
Water connections	Ø	VICTAULIC DN 100			VICTAULIC DN 125				VICTAULIC DN 150					
Max service pressure	bar	10 bar water side												
<b>Dimensions and weight</b>														
Storage temperature	°C	See section 1 Introduction												
Min water volume	l.	636	880	844	1146	1043	1346	1286	1735	1262	1336	1595		
Operating height ⑤	mm	1869						1887			1970			
Length	mm	2099						2499			3350			
Depth	mm	996												
Weight (empty)	kg	1044	1156	1189	1312	1363	1425	1613	1708	2284	2376	2418		
Weight in working order	kg	1088	1205	1246	1378	1436	1510	1713	1818	2472	2588	2637		
<b>Electrical supply</b>														
Compressor voltage	ph/Hz/V	3 / 50 Hz / 400 V (+10 % / -10 %)												
Protection machine rating		IP 21												
Protection electrics box		IP 21												
Max. rated current	A	140	160	182	205	218	232	266	295	356	399	443		
Starting current	A	316	334	391	414	480	494	586	615	607	720	763		
Starting current, Soft Start option ⑥	A	230	248	287	310	352	366	429	453	483	562	605		
Breaking capacity	kA	40.5						61.5				70		
Max. wire cross-section	mm²	240												
Control circuit voltage	ph/Hz/V	1 / 50 Hz / 230 V (+10 % / -10 %) - Transformer assembled												
Max. rated current	A	0.8						1.3						
Transformer power	VA	160						250						

① Cooling capacities for chilled water temperature +12°C / +7°C and condenser hot water temperature +30°C / +35°C

② Compressor net power input

③ COP performance, EER or ESEER efficiency values

④ LW: Overall power level, as per ISO standard 3744.

Lp: Overall pressure levels measured at 10 m in a free field, calculated using the formula LP=Lw- 10 log (S)





⑤ Height excluding handling mounts

⑥ Starting current of largest compressor + maximum current of other compressors under full load

Cable selection nominal current = Sum of maximum rated currents in the above tables.

## 19. SERVICING AND MAINTENANCE

### 19.1 Operating readings for DYNACIAT et DYNACIAT<sup>power</sup>

Date/Time							
<b>Compressor</b>	Suction pressure	bar					
	Intake temperature	°C					
	Condensation pressure	bar					
	Condensation temperature	°C					
<b>Water cooled condenser</b>	Discharge inlet temperature	°C					
	Liquid outlet temperature	°C					
	Water inlet temperature	°C					
	Water outlet temperature	°C					
<b>Evaporator</b>	Water inlet temperature	°C					
	Water outlet temperature	°C					
	Liquid inlet temperature	°C					
	Evaporator outlet temperature	°C					
<b>Rated voltage</b>	V						
<b>Terminal voltage</b>	V						
<b>Compressor input current</b>	A						
<b>Oil level</b>							
<b>Frost protection trigger temperature</b>	°C						
<b>Mechanical check: pipes, screws, etc.</b>							
<b>Electrical connection tightness check</b>							
<b>Control check</b>							
<b>Water flow rate check</b>	m <sup>3</sup> /h						
<b>H. P. safety disconnection check</b>	bar						

### 19.2 Unit maintenance and servicing

#### 19.2.1 Safety instructions

- Perform operating inspections in accordance with national regulations.
- Do not climb on the machine; use a platform to work at the necessary height.
- Do not climb on the copper refrigerant pipes.
- All work on the unit's electrical or refrigerant systems must be carried out by a qualified authorised technician.
- Any opening or closing of a shut-off valve must be carried out with the unit off.
- The liquid valve (located just before the dryer) must always be opened completely when there is refrigerant in the circuit.
- **Do not work** on any electrical components without first **turning off the main cutoff switch** in the electrics box. Although the compressor(s) is (are) turned off, the power circuit remains energised until the unit cutoff switch is opened. Other components may remain energised by external controllers connected to the orange disconnect terminals on the main terminal strip.

Disconnect the removable portion of these terminals before commencing any work.

- The surfaces of the compressor and pipes may reach temperatures of over 100°C and cause burns if touched.

Likewise, the surfaces of the compressor may in some cases drop to freezing temperatures which can cause frostbite.

- It is therefore important to take special care when carrying out maintenance work.
- Technicians working on the unit must wear the necessary safety gear (e.g. gloves, eye protection, insulating clothing, safety shoes).

#### 19.2.2 Noise

Similarly, it is recommended that personnel working close to sources of high noise emission wear ear defenders.

The ear defenders should in no way impede the wearing of other protective equipment.

#### 19.2.3 Oil

Oils for refrigeration units do not pose any health risks if they are used in compliance with the precautions for use:

- Avoid unnecessary handling of components lubricated with oil.

Use protective creams.

- Oils are flammable and must be stored and handled with care. Disposable rags or cloths used in cleaning must be kept away from open flames and disposed of in the appropriate manner.
- Containers must be stored with their caps on. Avoid using oil from an opened container stored under poor conditions.

### 19.2.4 Refrigerants - general information

- Always remember that refrigeration systems contain pressurised liquids and vapours.  
All necessary provisions must be made when the system is partially opened: ensure the part of the circuit concerned is not pressurised.
- Partial opening of the primary refrigerant circuit will cause a certain quantity of refrigerant to be released into the atmosphere.
- It is essential to keep the amount of lost refrigerant as low as possible by pumping the charge and isolating it in another part of the system.
- The refrigerant and lubricating oil, and the low-temperature liquid refrigerant in particular, may cause inflammatory lesions similar to burns if they come into contact with the skin or eyes.  
Always wear protective eyewear, gloves and other protective equipment when opening pipes or tanks liable to have liquids in them. Store unused refrigerant in the appropriate containers and limit the amounts stored in mechanical rooms.
- Cylinders and tanks of refrigerant must be handled with care and signs warning users of the related poisoning, fire and explosion hazards must be clearly visible. Refrigerant that reaches the end of its life must be collected and recycled in accordance with applicable regulations.

### 19.2.5 Halocarbon and hydrofluorocarbon refrigerants

Although non-toxic, vapours from halocarbon and hydrofluorocarbon refrigerants remain hazardous because they are heavier than air and can force the latter out of mechanical rooms.

If refrigerant is accidentally released, ventilate the room with fans. Exposure levels in workplaces must be kept to a practical minimum and must never exceed the recognised limit of 1000 ppm for an 8-hour working day and a 40-hour working week. Although halocarbon and hydrofluorocarbon refrigerants are not inflammable, open flames (e.g.: cigarettes, etc.) are prohibited as temperatures over 300°C cause these vapours to decompose and cause phosgene, hydrogen fluoride, hydrogen chloride and other toxic compounds to be formed. These compounds may produce severe physiological consequences if accidentally inhaled or swallowed.

**Warning:** Do not expose R410A, R407C vapours and zeotropic blends of refrigerants containing R32 to open flames (such as cigarettes). Refrigerants must be evacuated from pipes and tanks before commencing any cutting or welding work. Do not use a torch to check for leaks of refrigerants containing halocarbons such as R410A, R407C and its by-products.

**NOTE:** The DYNACIAT LG 120V to 600V and the DYNACIAT<sup>power</sup> 700V to 2400V are machines that operate with R410A. It is **essential** that technicians use equipment which is compatible with R410A with a working pressure which is approximately 1.5 times higher than that of units using R407C.

### 19.2.6 Servicing

- Note down the operating readings and perform the checks indicated in the table on the previous page at least twice a year and **each time** a unit is started up.

#### • Weekly checks

With the unit running at full capacity, check the following values:

- Check the entire system for traces of water or oil under or around the unit and for any unusual noises.
- LP compressor suction pressure,
- HP compressor discharge pressure,

- The water inlet and outlet temperatures in the exchangers
- The charge via the liquid sight glass and the condition of the charge using the coloured indicator on the sight glass
- The oil level and its appearance. If the colour changes, check the quality.
- Keep the unit clean.

#### • Monthly checks

- Check all the values listed in the «Operating readings» table on the previous page.
- Perform a corrosion check on all the metal parts. (Frame, casing, exchangers, electrical boxes etc.)
- Make sure that the insulating foam is neither detached nor torn.
- Check the coolants for any impurities which could cause wear or corrosion in the exchanger.
- Check the circuits for leaks.
- Check whether the safety devices and the expansion valve(s) operate correctly every 6 months.

#### • Annual checks

- Carry out the same inspections as during the monthly checks.
- Carry out an oil contamination test: if acid, water or metal particles are found, replace the oil in the circuit concerned and the dryer.
- If all the oil must be emptied, replace it solely with new oil of the same grade as the original oil and stored in a hermetically sealed container until its time of use. (Oil type: see section 12 «Main components of the refrigerating circuit»).
- Check the filter dryer for clogging (measure the difference in the temperature of the pipes at the dryer inlet and outlet).
- Clean the water filter and vent air from the circuit.
- Clean the exchangers and check the pressure drop in each.
- Check the operation of the water flow switch.
- Check the water quality or condition of the coolant.
- Check the antifreeze concentration (MEG or PEG)
- Disconnect all the cables for check the insulation of the motor and the resistance of the coils.
- Check the electrical connections to ensure they are tight and in good condition.
- Check the condition of the contacts and the current at full load on all three phases.
- Check the electrical box for water seepage.

**NOTE: The intervals for cleaning are given as a guide and should be adapted to each unit.**

### 19.2.7 Disassembling the compressor

The compressor is fastened to the platform by four dia. 8 mm screws.

**N.B.:** When tightening the compressor bolts, the maximum torque to apply is 13 Nm ± 1 for the **DYNACIAT** and 16 Nm ± 1 for the **DYNACIAT<sup>power</sup>**. If you do not have a torque wrench, tighten until you feel some resistance, then tighten a further ¼ of a turn.

#### **IMPORTANT:**

**To ensure your unit runs smoothly and to obtain service under the warranty, take out a maintenance contract with your installer or an approved maintenance company.**

## 20 ECODESIGN

The sealing test must be carried out in compliance with EC regulation no. 517/2014 relating to certain greenhouse gases. R410A, R134a and R407C are refrigerant gases with the following environmental impact:

1/ No impact on the ozone layer.

They have an ODP (Ozone Depletion Potential) index of 0

2/ Impact on the greenhouse effect: Global Warming Potential (GWP) of each gas.

- R410A ----- GWP = 2088

- R407C ----- GWP = 1800

- R134a ----- GWP = 1430

- Users must ensure that periodic leak testing is carried out by qualified personnel based on the number of tonnes of CO<sub>2</sub> equivalent:

		≥ 5 tCO <sub>2</sub> eq	≥ 50 tCO <sub>2</sub> eq	≥ 500 tCO <sub>2</sub> eq
Frequency of check	Without leak detection system	Every 12 months	Every 6 months	Every 3 months
	With leak detection system	Every 24 months	Every 12 months	Every 6 months
Refrigerant charge*	R410A (GWP = 2088)	≥ 2.39 kg	≥ 23.9 kg	≥ 239 kg
	R407C (GWP = 1800)	≥ 2.77 kg	≥ 27.7 kg	≥ 277 kg
	R134a (GWP = 1430)	≥ 3.49 kg	≥ 34.9 kg	≥ 349 kg

\* To find out the refrigerant charge and the number of tonnes of CO<sub>2</sub> equivalent, refer to the technical characteristics in the unit's instruction manual.

- Users of any system subject to leak testing are required to keep a log of the quantities and types of fluids used, (added or recovered), and to include the dates and results of leak tests, as well as the name of the technician and the technician's company.

- A leak test must be carried out one month after any leak repairs.

- System users are responsible for collecting used refrigerant and having it recycled, regenerated or destroyed.

## 21 PERMANENT SHUTDOWN

### ➤ Shutting down

- Separate the units from their energy sources, allow them to cool then drain them completely.

### ➤ Recommendations for disassembly

- Use the original lifting equipment.

- Sort the components according to their material for recycling or disposal, in accordance with regulations in force.

- Check whether any part of the unit can be recycled for another purpose.

### ➤ Fluids to be recovered for treatment

- R410A refrigerant

- Energy transfer fluid: depending on the installation, water, glycol/water mix...

- Compressor oil

### ➤ Materials to be recovered for recycling

- Steel

- Copper

- Aluminium

- Plastics

- Polyurethane foam (insulation)

### ➤ Waste electrical and electronic equipment (WEEE)

- At the end of its life, this equipment must be disassembled and contaminated fluids removed by professionals and processed via approved channels for electrical and electronic equipment (WEEE).

- In France, CIAT has formed a partnership with ECOLOGIC for the collection and recovery of professional waste governed by European Directive WEEE 2012/19/EU. This partnership simplifies the mandatory administrative procedures and ensures that old equipment is recovered via an official, structured channel. In terms of renovation work in France (mainland and overseas), for every CIAT unit installed, our partner will collect and dismantle your existing equipment (see conditions with Ecologic). To request collection, please contact Ecologic: 01.30.57.79.14 - operation-pro@ecologic-france.com

- For other countries, please refer to the legislation in force and the specific solutions available to ensure your waste is processed legally.

## 22 TROUBLESHOOTING OPERATING PROBLEMS

### Initial advice:

- Faults detected by the safety devices are not necessarily caused by a sudden change in the measurement being monitored.

- Taken regularly, readings should make it possible to anticipate future trips.

- Perform the checks listed in the table below (next page) if you notice that a measurement deviates from its normal value and gradually moves closer to the safety limit.

**Important:** First and foremost, bear in mind that most faults that occur on the units have simple causes that are often the same for all. Look for these causes first.

There are three such causes in particular:

- Exchanger fouling

- Problems with the fluid circuits

- Failures of electric components such as the relay coil or the electric valve etc.



<b>Faults</b>	<b>Probable causes</b>	<b>Instructions</b>
<b>Suction pressure too low</b>	<ul style="list-style-type: none"> <li>Air in the chilled water circuit.</li> <li>- Chilled water flow insufficient.</li> <li>- Chilled water flow sufficient but chilled water temperature too low.</li> <li>- Lack of refrigerant fluid..</li> </ul>	<ul style="list-style-type: none"> <li>- Purge the chilled water circuit.</li> <li>- Check the opening of the chilled water circuit valves.</li> <li>- Check the direction of rotation of the pump, that there is no cavitation and that the pump is not too small.</li> <li>- Recalculate the heat load and check that the unit is not too powerful for this load.</li> <li>- Check the operation of the regulator.</li> <li>- Trace the leak(s) and top up the charge.</li> </ul>
<b>Excessive discharge pressure</b>	<ul style="list-style-type: none"> <li>- Air in the hot water circuit.</li> <li>- Insufficient hot water flow.</li> <li>- Cooling water flow sufficient but water temperature too high.</li> <li>- Incorrect operation of the tower or drycooler.</li> <li>- Clogged or scaled condenser.</li> <li>- Too much refrigerant..</li> </ul>	<ul style="list-style-type: none"> <li>- Drain the hot water circuit.</li> <li>- Check the opening of the hot water circuit valves.</li> <li>- Check the direction of rotation of the pump, that there is no cavitation and that the pump is not too small.</li> <li>- Recalculate the heat load and check that the unit is not too powerful for this load.</li> <li>- - Check correct operation of the regulator and setpoint adjustment.</li> <li>- Check the operation of the tower or drycooler.</li> <li>- Check the control of cooling water temperature.</li> <li>- Clean the condenser tubes.</li> <li>- Check and adjust the charge..</li> </ul>
<b>Insufficient oil</b>	<ul style="list-style-type: none"> <li>- Oil not topped up after servicing.</li> </ul>	<ul style="list-style-type: none"> <li>- Top up with oil..</li> </ul>
<b>Water flow fault</b>	<ul style="list-style-type: none"> <li>- Water flow is either stopped or below the minimum rate.</li> </ul>	<ul style="list-style-type: none"> <li>- Check that the valves on the water circuit open and check the pump(s)..</li> </ul>
<b>Motor winding fault.</b>	<ul style="list-style-type: none"> <li>- Start-ups too close together; short-cycle protection not working properly..</li> <li>- Overload protection disrupted or defective.</li> <li>-Insufficient power supply voltage.</li> </ul>	<ul style="list-style-type: none"> <li>- Set the correct time between two starts.</li> <li>- Adjust or replace the overload protection.</li> <li>- Check the electrical wiring; if need be, contact your electricity supplier.</li> </ul>
<b>Fluid outlet temperature too high</b>	<p>a) With above-normal low pressure</p> <ul style="list-style-type: none"> <li>- Incorrect regulator setpoint.</li> <li>- Heat load above unit capacity.</li> <li>- Water flow rate too high.</li> </ul> <p>- Faulty electronic regulation.</p> <p>b) With below-normal low pressure</p> <ul style="list-style-type: none"> <li>- Lack of refrigerant.</li> <li>- Incorrect refrigerant supply to evaporator.</li> </ul>	<ul style="list-style-type: none"> <li>- Correct the setpoint value.</li> </ul> <p>Two solutions:</p> <ul style="list-style-type: none"> <li>- Adjust the water flow rate to the value specified using the control valve.</li> <li>- Bypass the evaporator to obtain a greater difference in temperature with a lower flow rate to the evaporator.</li> </ul> <ul style="list-style-type: none"> <li>- Check the operation of the temperature and output regulators.</li> <li>- Look for leaks and top up the charge of refrigerant.</li> <li>- Check the expansion valve.</li> <li>- Ensure that the dryer filter is not clogged and that the evaporator is not frozen.</li> </ul>
<b>Discharge temperature insufficient and near condensing temperature</b>	<ul style="list-style-type: none"> <li>- The compressor draws in too much liquid.</li> </ul>	<ul style="list-style-type: none"> <li>- Check and adjust the refrigerant charge.</li> <li>- Check the expansion valve.</li> </ul>
<b>Humidity indicator light</b>	<ul style="list-style-type: none"> <li>- The sight glass remains yellow: excessive moisture in the circuit.</li> </ul>	<ul style="list-style-type: none"> <li>- See section 12 "Main components of the refrigerant circuit".</li> </ul>

## 23 INSTALLATION DIAGRAM FOR DYNACIAT AND DYNACIAT<sup>power</sup> LG, LGP

### 23.1 Cooling installation with drycooler

#### DYNACIAT

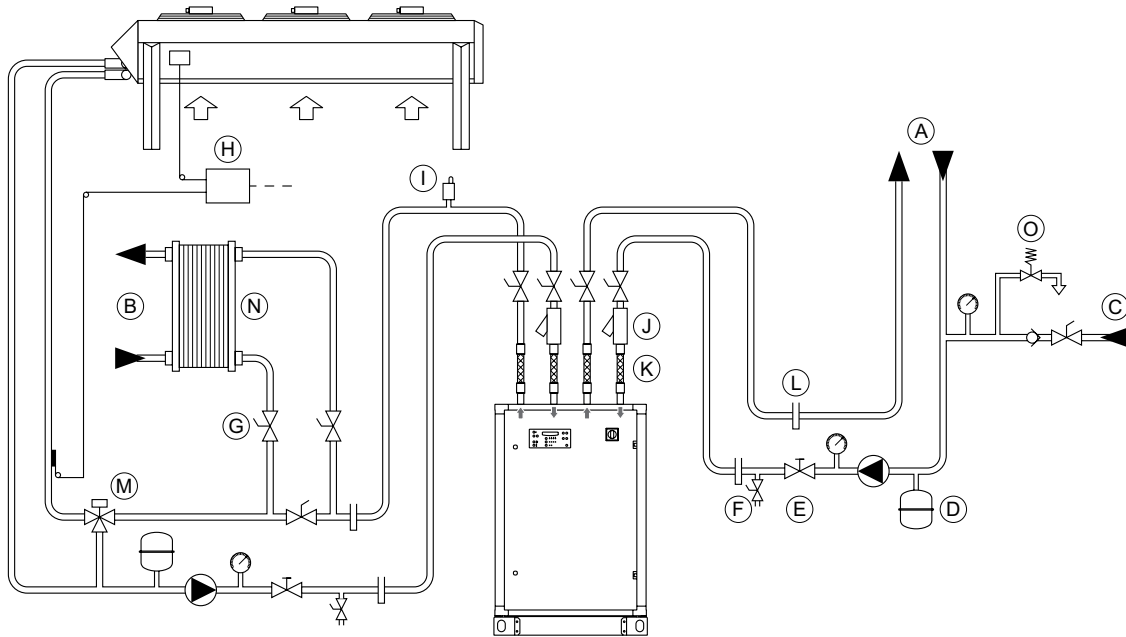

#### DYNACIAT<sup>power</sup>

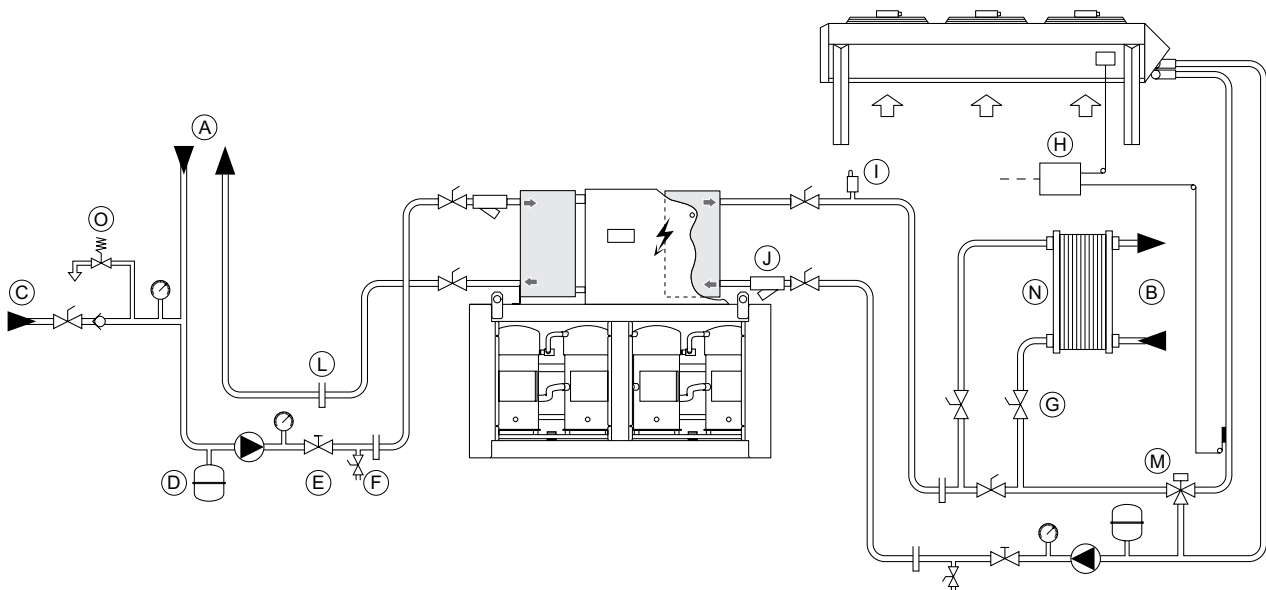

**A:** Chilled water circuit  
**B:** Recovery water circuit  
**C:** Water top-up  
**D:** Expansion vessel  
**E:** Control valve

**F:** Drain  
**G:** Shut-off valve  
**H:** Temperature controller  
**I:** Air bleed  
**J:** Water filter (Compulsory)

**K:** Water hoses  
 (Compulsory on DYNACIAT)  
**L:** Temperature measuring well  
**M:** Hydraulic 3-way valve  
**N:** Cleanable exchanger  
**O:** Pressure relief valve

**23.2 Cooling mode (Heating and cooling)**

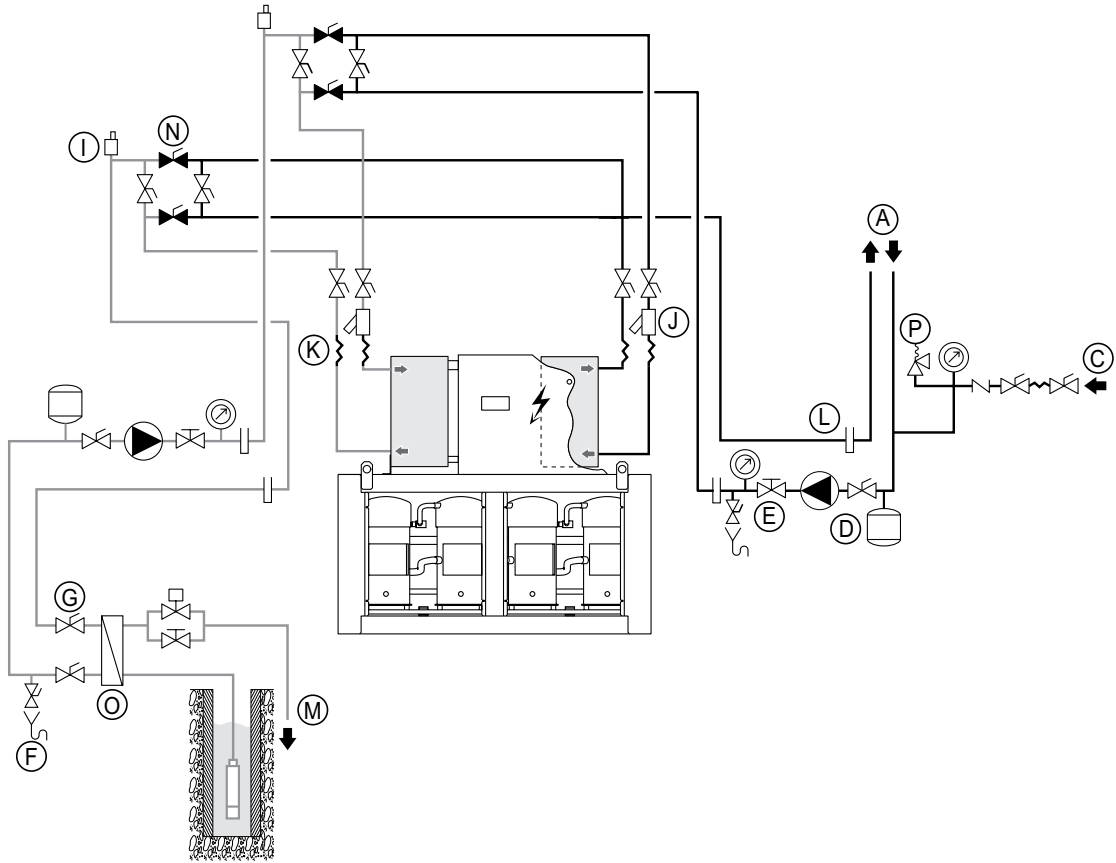

**23.3 Heating mode (Heating and cooling)**

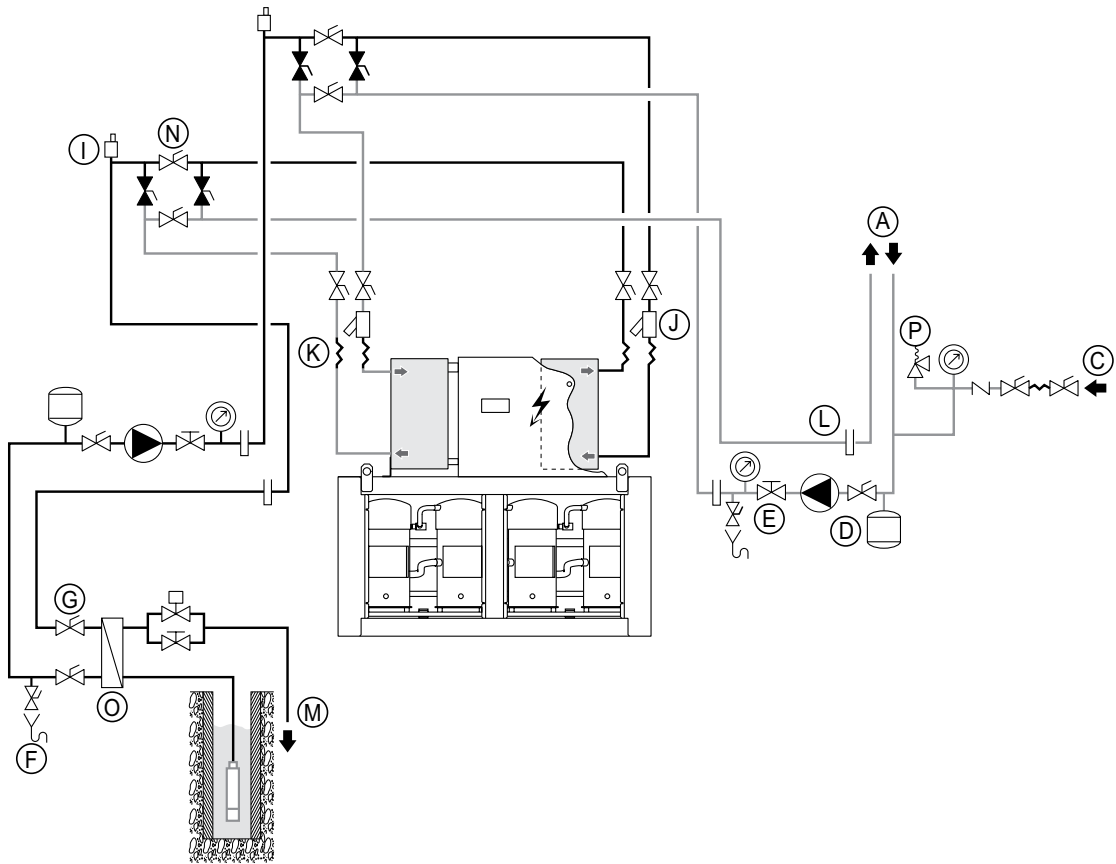

- |   |                                     |                                     |
|---|-------------------------------------|-------------------------------------|
| <b>A</b> : Chilled or hot water circuit | <b>G</b> : Shut-off valve           | <b>M</b> : Well discharge           |
| <b>C</b> : Water supply valve           | <b>I</b> : Air bleed valve          | <b>N</b> : Hydraulic valve          |
| <b>D</b> : Expansion vessel             | <b>J</b> : Water filter (mandatory) | <b>O</b> : Cleanable heat exchanger |
| <b>E</b> : Control valve                | <b>K</b> : Water hoses (mandatory)  | <b>P</b> : Safety valve             |
| <b>F</b> : Drain                        | <b>L</b> : Thermowell               |                                     |



**Siège social**

Avenue Jean Falconnier B.P. 14  
01350 Culoz - France  
Tel. : +33 (0)4 79 42 42 42  
Fax : +33 (0)4 79 42 42 10  
info@ciat.fr - www.ciat.com

**Compagnie Industrielle  
d'Applications Thermiques**  
S.A. au capital de 26 728 480 €  
R.C.S. Bourg-en-Bresse B 545.620.114



ISO9001 • ISO14001  
OHSA 18001

**CIAT Service**  
[www.ciat.fr](http://www.ciat.fr)

Document non contractuel.

Dans le souci constant, d'améliorer son matériel, CIAT se réserve le droit de procéder sans préavis à toutes modifications techniques.

Non-contractual document. With the thought of material improvement always in mind, CIAT reserves the right, without notice to proceed with any technical modification.

Dieses Dokument ist keine Vertragsunterlage.

Da wir ständig bemüht sind, unser Material noch weiter zu verbessern, behält sich CIAT das Recht vor, technische Änderungen ohne vorherige Ankündigung vorzunehmen.

Documento no contractual. En la preocupación constante de mejorar su material, CIAT se reserva el derecho de proceder, sin previo aviso, a cualquier modificación técnica.

Documento non contrattuale. Nella preoccupazione costante di migliorare il suo materiale, CIAT si riserva il diritto di procedere senza preavviso a tutte le modificazioni tecniche necessarie.